

客户： 有限公司	品名： PA66 束线带 GN-*** / 各色 (ROHS2.0)					
名称： <u>产品交货规格书</u>	承 認	高	检 查	解	作 成	李

品名 PA66 束线带 GN-***

客户签字栏：

制 定	2019-10-28
改 訂	2021-12-01
改 訂	2023-5-10 追加不锈钢嵌片锁紧扎带

上海高昊配线器材有限公司

地址：上海市青浦区新胜路 238 号 7 幢

Add: Building 7, NO. 238, Xinsheng RD, Qingpu Dist, Shanghai City, China.

Tel: 021-59788045 Fax: 021-59788053

Http: ①shgaohaoi.1688.com ②www.gaohaocn.com



产品规格书

束线带系列 (Cable Tie Series)



产品交货规格书

1. 适用范围

本规格书，适用于向_____有限公司提供的，由上海高昊配线器材有限公司制造的，有关 PA66 束线带 GN-***的各项规定。

2. 性质

主成分: PA66

颜色: 各种颜色

3. 品质规格

请参照束线带尺寸规格表

4. 检查成绩书的提交

根据_____有限公司的要求来提供。

5. 检查方法

I 外观检查: 出货时从每箱中抽取两包做以下检验

检查项目: 1, 包装袋依指定规格、印刷需正确 2, 不可有封袋不良、漏气、袋内异物等不良 3, 产品不可有变黄、粉末、毛边

II 按照品质规格, 测出其长度、宽度、肉厚

长度、宽度、肉厚测定工具: 数码游标尺。

6. 包装

参照附件按规定的数量, 内用 PE 袋包装并密封、外用纸箱包装。

7. 表示

按照本公司规定的标签来表示品名, 规格, 数量, 生产日期/批号, 有效期, 存储条件。

8. 束线带存储方法、测试规范及客户使用注意事项

存储环境在常温状态下应避免阳光直射、遮光保存, 使用前不要打开包装袋。

9. 规格书的修改

关于本规格书的修改, 在其一方的提出下, 双方应共同协商修改。

10. 其它

本规格书一式两份, 1 部分请确认后在客户签字栏里盖章反馈过来。

► Cable Tie
束线带

- Operating temperature: -40°C to 85°C (-40°F to 185°F)
- Heat material could reach to 120°C
- Specification: UL approved, UV, Heat Resistant,
Color are available
- Material: UL approved nylon 66 94V-2
- Color: All color available
- package: 1000 or 100 pcs/bag
- Unit: mm (inch)
- 操作温度: -40°C to 85°C (-40°F to 185°F)
耐热材质可达到120°C
- 说明: UL认证, 耐候、耐热、耐寒及不同颜色材质皆可做。
- 材质: 尼龙66, 防火等级94V-2
- 颜色: 各种颜色皆可。
- 包装: 1000或100个/包
- 单位: 毫米(英寸)。





E314653

Part No.		Approx. Length mm (inch)	Approx. Width mm (inch)	Max. Bundle Dia. mm (inch)	Min. Loop Tensile Strength kg (lbs)	Recommend Crimping Tools
1000 pcs/bag	100 pcs/bag					
GN-80M	GN-80MC	80(3.15)	2.4(0.09)	15(0.59)	8.0(17.68)	 GIT-701
GN-90M	GN-90MC	90(3.54)		16(0.63)		
GN-100M	GN-100MC	100(3.94)	2.5(0.10)	22(0.87)	8.1(18)	
GN-120M	GN-120MC	120(4.72)		30(1.18)		
GN-140M	GN-140MC	140(5.51)		33(1.30)		
GN-150M	GN-150MC	150(5.91)		35(1.38)		
GN-160M	GN-160MC	160(6.30)		38(1.50)		
GN-200M	GN-200MC	200(7.87)		53(2.09)		

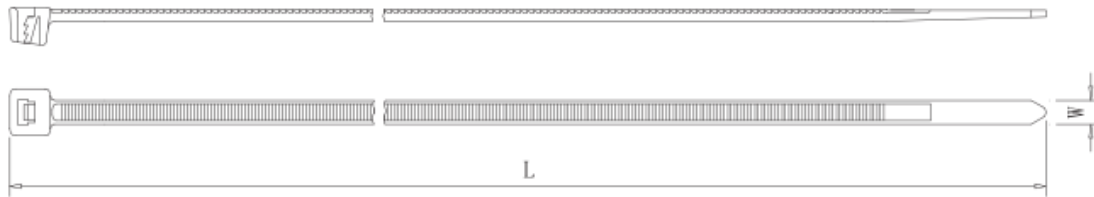

GN-250M	GN-250MC	250(9.84)	2.8(0.11)	65(2.56)	14(31)	 GIT-701
GN-300M	GN-300MC	300(11.81)		76(2.99)		



Part No.		Approx.Length mm(inch)	Approx.Width mm(inch)	Max.Bundle Dia. mm(inch)	Min.Loop Tensile Strength kg(lbs)	Recommend Crimping Tools
1000pcs/bag	100pcs/bag					
GN-120I	GN-120IC	120(4.72)	3.6(0.14)	30(1.18)	18.2(40)	 GIT-702P
GN-140I	GN-140IC	140(5.51)		33(1.30)		
GN-150I	GN-150IC	150(5.91)		35(1.38)		
GN-180I	GN-180IC	180(7.09)		44(1.73)		
GN-200I	GN-200IC	200(7.87)		52(2.05)		
GN-215I	GN-215IC	215(8.46)		56(2.20)		
GN-250I	GN-250IC	250(9.84)		65(2.56)		
GN-300I	GN-300IC	300(11.81)		76(2.99)		

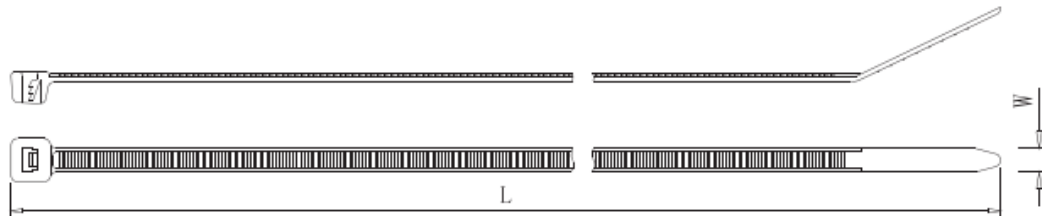

GN-370I	GN-370IC	370(14.57)	3.6(0.14)	102(4.02)	18.2(40)	 GIT-702P
---------	----------	------------	-----------	-----------	----------	---

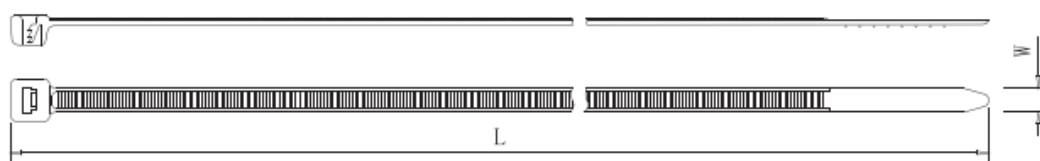

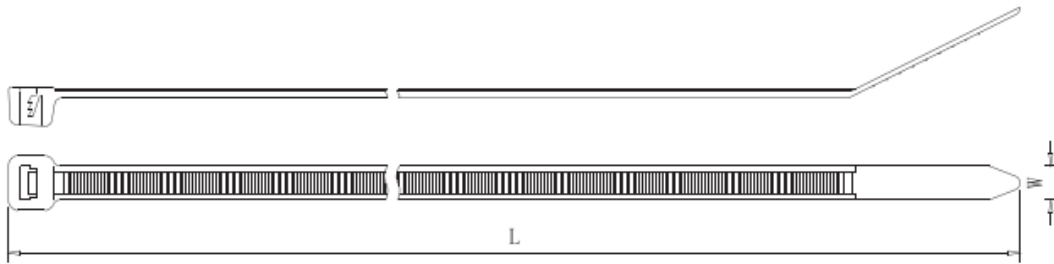

GN-120ST	GN-120STC	120(4.72)	4.8(0.19)	24(0.94)	22.2(50)	 GIT-702M
GN-150ST	GN-150STC	150(5.91)		35(1.38)		
GN-160ST	GN-160STC	160(6.30)		38(1.50)		
GN-190ST	GN-190STC	190(7.48)		46(1.81)		
GN-200ST	GN-200STC	200(7.87)		50(1.97)		
GN-215ST	GN-215STC	215(8.46)		53(2.09)		
GN-250ST	GN-250STC	250(9.84)		60(2.36)		
GN-265ST	GN-265STC	265(10.43)		65(2.56)		
GN-280ST	GN-280STC	280(11.02)		70(2.76)		
GN-300ST	GN-300STC	300(11.81)		76(2.99)		
	GN-370STC	370(14.57)	102(4.02)			



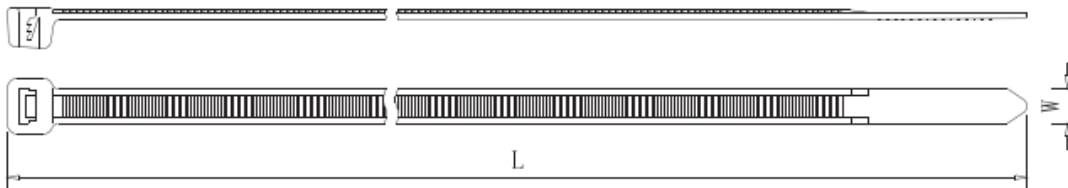

Part No.		Approx.Length mm(inch)	Approx.Width mm(inch)	Max.Bundle Dia. mm(inch)	Min.Loop Tensile Strength kg(lbs)	Recommend Crimping Tools
1000pcs/bag	100pcs/bag					
	GN-390ST	390(15.35)	4.8(0.19)	105(4.13)	22.2(50)	 GIT-702M
	GN-430ST	430(16.93)		110(4.33)		
	GN-450ST	450(17.72)		116(4.57)		
	GN-530ST	530(20.87)		140(5.51)		
	GN-550ST	550(21.65)		145(5.71)		
	GN-635ST	635(25.00)		190(7.48)		
	GN-685ST	685(26.97)		205(8.07)		

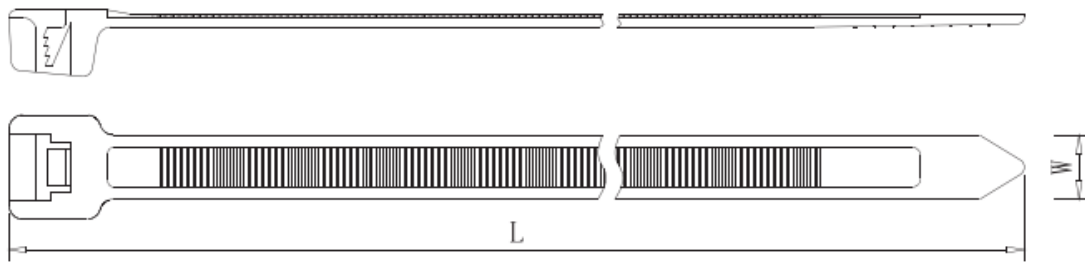

	GN-150HD	150(5.91)	7.6(0.30)	33(1.30)	54.4(120)	 GIT-704
	GN-200HD	200(7.87)		50(1.97)		
	GN-240HD	240(9.45)		63(2.48)		
	GN-250HD	250(9.84)		65(2.56)		
	GN-280HD	280(11.02)		71(2.79)		
	GN-300HD	300(11.81)		76(2.99)		
	GN-370HD	370(14.57)		102(4.02)		
	GN-430HD-S	430(16.93)		123(4.84)		
	GN-450HD-S	450(17.72)		132(5.20)		
	GN-530HD-S	530(20.87)		140(5.51)		
	GN-610HD-S	610(24.02)		180(7.09)		
	GN-710HD-S	710(27.95)		212(8.35)		

	GN-430HD	430(16.93)	9.0(0.35)	110(4.33)	79.4(175)	
	GN-450HD	450(17.72)		120(4.72)		
	GN-530HD	530(20.87)		140(5.51)		



Part No.		Approx.Length mm(inch)	Approx.Width mm(inch)	Max.Bundle Dia. mm(inch)	Min.Loop Tensile Strength kg(lbs)	Recommend Crimping Tools
1000pcs/bag	100pcs/bag					
	GN-610HD	610(24.02)	9.0(0.35)	182(7.17)	79.4(175)	
	GN-710HD	710(27.95)		190(7.48)		
	GN-780HD	780(30.71)		228(8.98)		
	GN-830HD	830(32.68)		239(9.41)		
	GN-920HD	920(36.22)		263(10.35)		
	GN-1020HD	1020(40.16)		295(11.61)		
	GN-1070HD	1070(42.00)		320(12.60)		
	GN-1220HD	1220(48.00)		365(14.37)		
	GN-1530HD	1530(60.23)		460(18.15)		

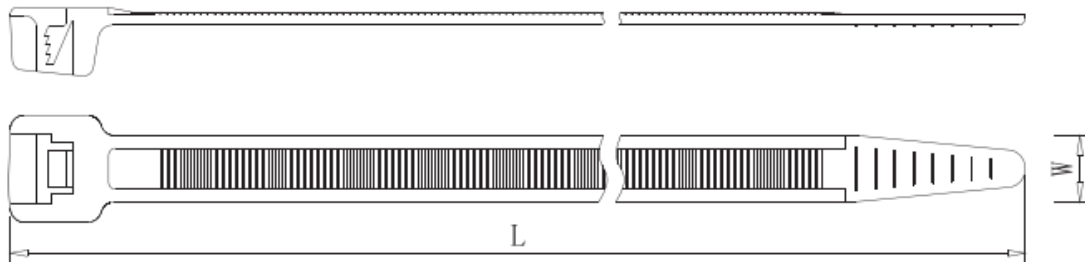

Cable tie ordering specification

GN	-	100	M	C	B	VO
<u>1</u>		<u>2</u>	<u>3</u>	<u>4</u>	<u>5</u>	<u>6</u>

1 Type 型号

2 Length 长度

3 Width 宽度: M=Miniature(小型), I=Intermediate(中型)
ST=Standard(标准型), HD=Heavy Duty(重拉力)
EHD=Extra Heavy Duty(超重拉力)

4 Package 包装: C=100pcs/bag(Others are 1000pcs/bag)
(若无注明: 为1000条/袋)

5 Color 颜色: Non=Natural(天然色), B=Black(黑色)
BR=Brown(褐色), RD=Red(红色)
OR=Orange(橘色), YL=Yellow(黄色)
GN=Green(绿色), BL=Blue(蓝色)
PP=Purple(紫色), GY=Gray(灰色)

6 Material 材质: UV=Ultra Violet weather resistant
tie for outdoor application
(适用于户外, 抗紫外线、耐候)
Heat=Heat Resistant(耐热)
VO=Fire-resistant(耐燃, 高防火等级)

产品规格书

束线带系列 (Cable Tie Series)

▶ ROUND HEAD TIE

▶ 圆头束线带

- Operating temperature:
-40°C to 85°C (-40°F to 185°F)
- Material:UL approved nylon 66 94V-2
- Color: All color available
- package:100pcs/bag
- Unit:mm(inch)
- 操作温度:-40°C to 85°C.
- 材质:尼龙66,防火等级94V-2
- 颜色:各种颜色皆可.
- 包装:100个/包
- 单位:毫米(英寸).



E314653

Part No.		Approx.Length mm(inch)	Approx.Width mm(inch)	Max.Bundle Dia. mm(inch)	Min.Loop Tensile Strength kg(lbs)
1000pcs/bag	100pcs/bag				
	GNE-430HD	430(16.93)	7.6(0.30)	110(4.33)	65(143)

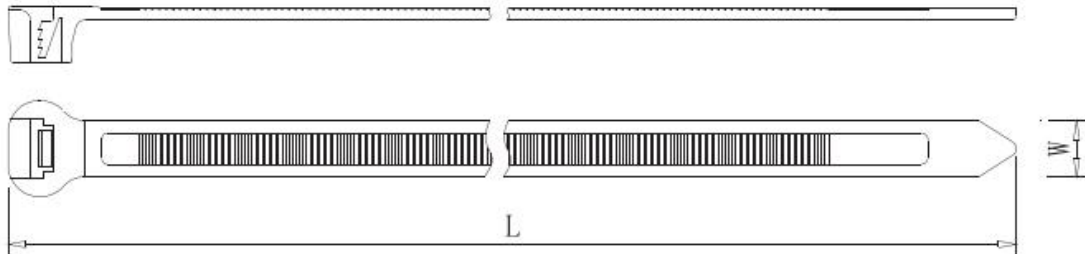

▶ RELEASABLE TIE

▶ 可退式束线带

- Easily assembled by hand
- Simple thumb release on head
- Ideal for temporary fastening
- Material:UL approved nylon 66 94V-2
- Color: All color available
- package:1000 or 100pcs/bag
- Unit:mm(inch)
- 特色:可再松开重复使用.
- 材质:尼龙66,防火等级94V-2
- 颜色:各种颜色皆可.
- 包装:1000或100个/包
- 单位:毫米(英寸).



E314653

Part No.		Approx.Length mm(inch)	Approx.Width mm(inch)	Max.Bundle Dia. mm(inch)	Min.Loop Tensile Strength kg(lbs)
1000pcs/bag	100pcs/bag				
GNR-140I	GNR-140IC	140(5.51)	3.6(0.14)	33(1.30)	18.2(40)

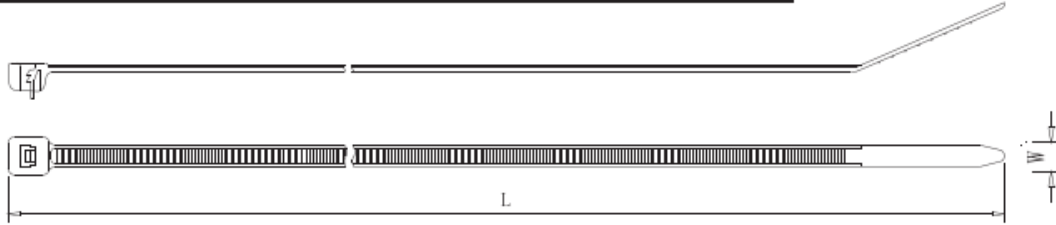

GNR-200ST	GNR-200STC	200(7.87)	4.8(0.19)	50(1.97)	22.2(50)
GNR-300ST	GNR-300STC	300(11.81)		76(2.99)	
	GNR-370ST	370(14.57)		104(4.02)	
	GNR-430ST	430(16.93)		120(4.72)	

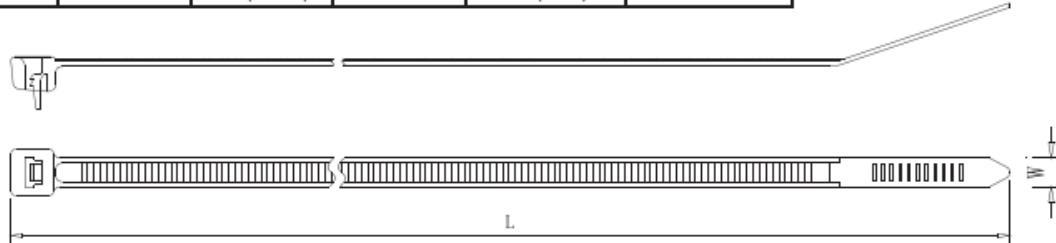

	GNRN-100HD	100(3.94)	7.6(0.30)	20(0.79)	22.2(50)
	GNRN-120HD	120(4.72)		30(1.18)	
	GNRN-150HD	150(5.91)		35(1.38)	
	GNRN-200HD	200(7.87)		50(1.97)	
	GNRN-250HD	250(9.84)		66(2.60)	
	GNRN-300HD	300(11.81)		80(3.15)	
	GNRN-370HD	370(14.57)		102(4.02)	

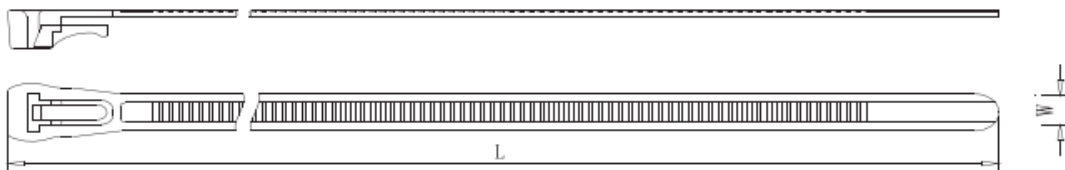

产品规格书

束线带系列 (Cable Tie Series)

▶ **EXTRA HEAVY DUTY TIE**

重拉力束线带

- Extra heavy duty ties for application where higher tensile strength is needed.
- Material: UL approved nylon 66 94V-2
- Color: All color available
- package: 100pcs/bag
- Unit: mm(inch)
- 特点: 超宽度设计, 承受力特强, 适合大电缆线捆绑使用.
- 材质: 尼龙66, 防火等级94V-2.
- 颜色: 各种颜色皆可.
- 包装: 100个/包
- 单位: 毫米(英寸)



E314653

Part No.	Approx.Length mm(inch)	Approx.Width mm(inch)	Max.Bundle Dia. mm(inch)	Min.Loop Tensile Strength kg(lbs)
100pcs/bag				
GN-230EHD	230(9.06)	12.6(0.50)	50(1.97)	114(250)
GN-290EHD	290(11.42)		76(2.99)	
GN-380EHD	380(14.96)		106(4.17)	
GN-480EHD	480(18.90)		120(4.72)	

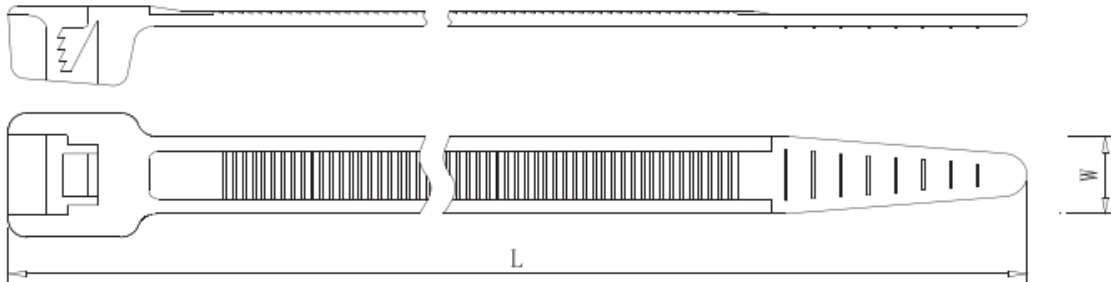

产品规格书

束线带系列 (Cable Tie Series)

► STOP TIE

- Material: UL approved nylon 66 94V-2 & nylon 6
- Color: All color available
- package: 1000 or 100pcs/bag
- Unit: mm(inch)
- 材质: 尼龙66, 防火等级94V-2 和尼龙6
- 颜色: 各种颜色皆可.
- 包装: 1000或100个/包
- 单位: 毫米(英寸).



E314653

Part No.	Material	Approx.Length mm(inch)	Approx.Width mm(inch)	Thickness mm(inch)	Max.Bundle Dia. mm(inch)	Min.Loop Tensile Strength kg(lbs)	Package (pcs/bag)
GN-100MA	Nylon 66	102(4.02)	2.5(0.10)	1.1(0.04)	22(0.87)	8.1(18)	1000
GN-150IA		150(5.91)					
GN-180IA		180(7.09)	3.6(0.14)	1.2(0.05)	44(1.73)	18.2(40)	

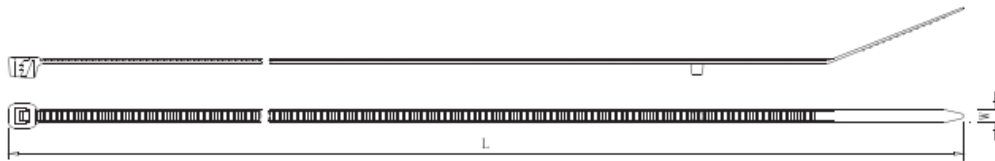

GN-300IA	Nylon 66	300(11.81)	3.6(0.14)	1.5(0.06)	82(3.23)	18.2(40)	1000
GN-600IA	Nylon 6	600(23.62)	2.4(0.09)		175(6.89)		
GN-800IA		800(31.50)	2.2(0.087)		235(9.25)	8.0(17.6)	500

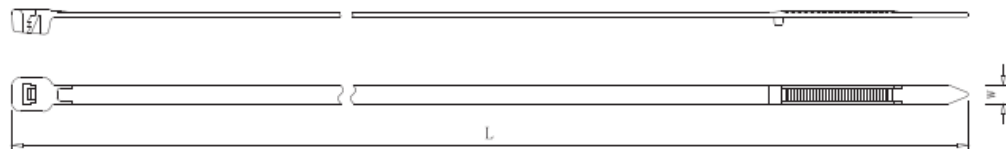

产品规格书

束线带系列 (Cable Tie Series)

► MOUNTABLE HEAD TIE
固定锁式束线带

- Can be secured the panel with a single bolt
- Material: UL approved nylon 66 94V-2
- Color: All color available
- package: 1000 or 100pcs/bag
- Unit: mm(inch)
- 特点: 束线带捆绑电线后, 可以用螺丝固定在基板上.
- 材质: 尼龙66, 防火等级94V-2.
- 颜色: 各种颜色皆可.
- 包装: 1000或100个/包
- 单位: 毫米(英寸).

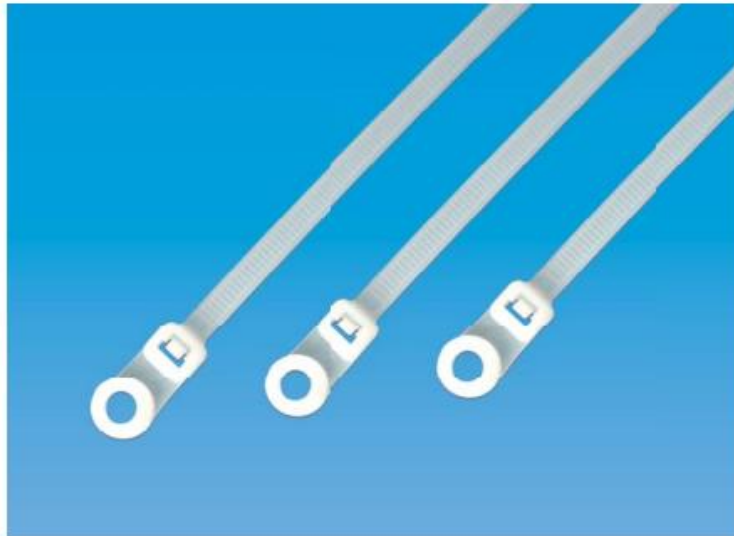

E314653

Part No.		Approx.Length mm(inch)	Approx.Width mm(inch)	Max.Bundle Dia. mm(inch)	Min.Loop Tensile Strength kg(lbs)	Hole Diameter	
1000pcs/bag	100pcs/bag					mm(inch)	screw
GNM-110M	GNM-110MC	110(4.33)	2.5(0.10)	22(0.87)	8.1(18)	ø3.2(0.126)	M3

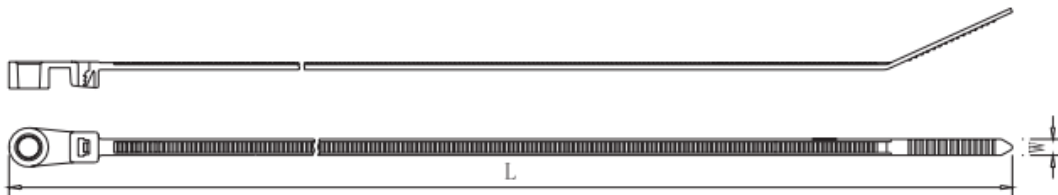

GNM-150I	GNM-150IC	150(5.91)	3.6(0.14)	32(1.26)	18.2(40)	ø4.2(0.165)	M4
----------	-----------	-----------	-----------	----------	----------	-------------	----

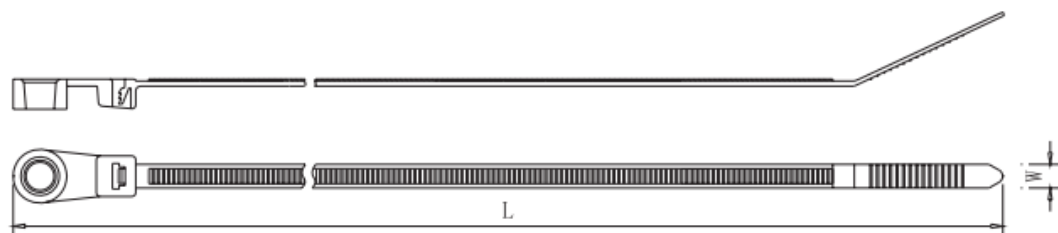

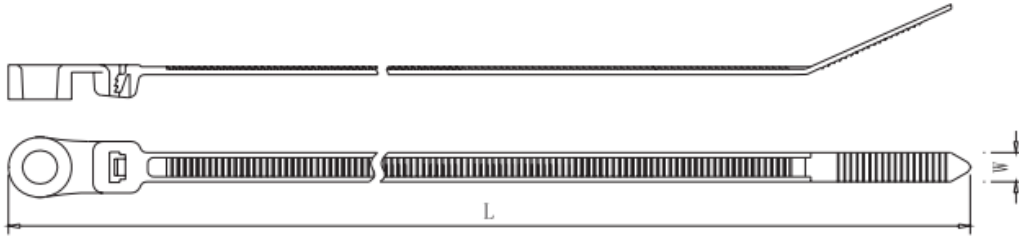

	GNM-200HD	215(8.46)	7.6(0.299)	50(1.97)	54.4(120)	ø5.7(0.224)	M5
	GNM-300HD	313(12.32)		76(2.99)		ø6.3(0.248)	M6
	GNM-380HD	380(14.96)		98(3.86)			

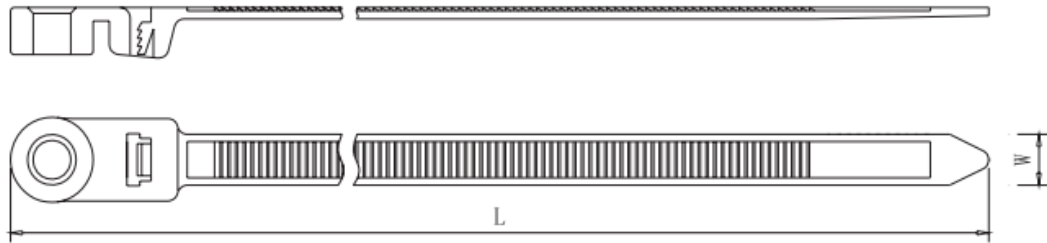

▶ **STAINLESS STEEL TIE**
钢制束线带

- Characteristic:
They have an unique ball locking mechanism that allow easily and quickly installed and not undone
- High tensile strength.
- Non-flammability.
- Operating temperature:-80℃~+500℃
- High resistance to acetic acid,alkali acid, sulphuric acid,corrode---etc.
- In eneral very resistant to most hostile environments.
- All length are available.
- Stainless steel type:301,304,316
- package:1000 or 100pcs/bag
- Unit:mm(inch)
- 特点：他们有一个独特的球锁机制，可以轻松和快速地安装，而不会散开。
- 抗拉强度高
- 不自燃
- 操作温度:-80℃~+500℃
- 抗乙酸醋酸，碱酸，硫酸，腐蚀---等。
- 适应各种恶劣的环境
- 长度:各种长度皆可制作
- 不锈钢材质:301,304,316
- 包装:1000或100个/包
- 单位：毫米(英寸).



Part No.	Approx.Length mm(inch)	Approx.Width mm(inch)	Max.Bundle Dia. mm(inch)	Min.Loop Tensile Strength kg(lbs)	Recommend Crimping Tools
100pcs/bag					
MLG-130ST	129(5.08)	4.5(0.18)	33(1.3)	46(101.2)	 GIT-705
MLG-200ST	200(7.87)		50(1.97)		
MLG-300ST	300(11.81)		76(2.99)		
MLG-370ST	370(14.57)		102(4.02)		
MLG-520ST	520(20.47)		156(6.14)		
MLG-680ST	680(26.77)		207(8.15)		
MLG-840ST	840(33.07)		257(10.1)		
MLG-200HD	197(7.76)	7.94(0.31)	50(1.97)	114(250.8)	
MLG-300HD	300(11.81)		76(2.99)		
MLG-370HD	368(14.49)		102(4.02)		
MLG-450HD	450(17.72)		135(5.31)		
MLG-500HD	500(19.69)		150(5.93)		
MLG-680HD	680(26.77)		207(8.15)		
MLG-840HD	840(33.07)		257(10.1)		
MLG-1020HD	1020(40.16)		312(12.3)		

▶ **BEAD TIE**

珠孔束线带

- Hole diameter: $\varnothing 3.0(0.118)$
- Material: PE or nylon 66 94V-2(V-O available)
- Panel thickness: $\sim 1.6\text{mm}(0.063)$
- Resuable, easy to install and release
- Color: All color available
- package: 1000pcs/bag
- Unit: mm(inch)
- 特点: 易重复组装使用.
- 头部尺寸: $3.0(0.118)$
- 材质: PE或尼龙66, 防火等级94V-2(V0亦可用).
- 厚度: $\sim 1.6\text{mm}(0.063)$
- 颜色: 各种颜色皆可.
- 包装: 1000个/包
- 单位: 毫米(英寸).



Part No.	Approx.Length mm(inch)	Approx.Width mm(inch)	Max.Bundle Dia. mm(inch)	Min.Loop Tensile Strength kg(lbs)
1000pcs/bag				
GNB-100	106(4.17)	2.3(0.09)	29(1.14)	4(8.8)
GNMB-90	93(3.66)		25(0.98)	

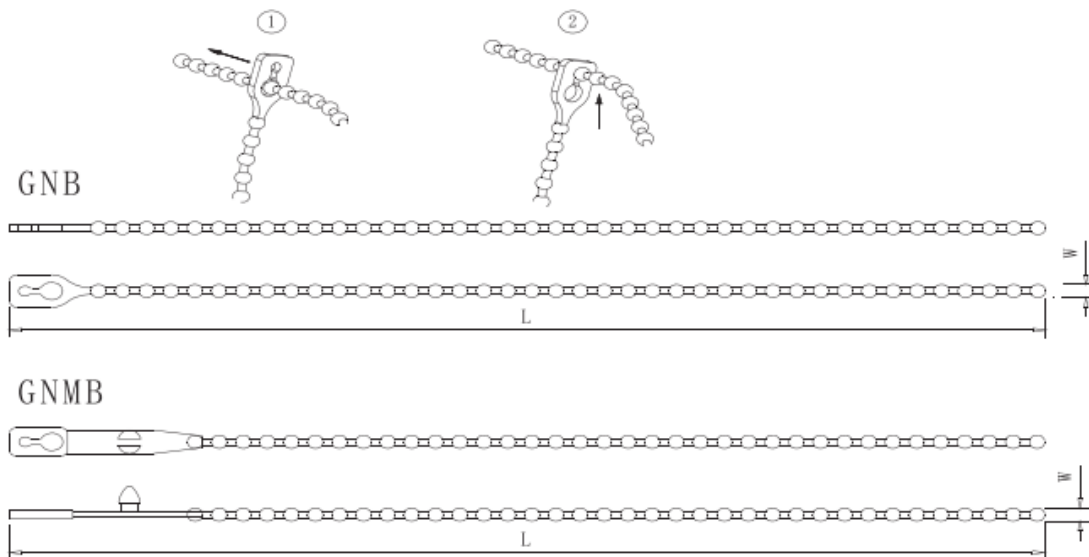

产品规格书

束线带系列 (Cable Tie Series)

► POLYAMID 11/12 TIE

尼龙11/12束线带

- Prolongs useful life of cable tie under sunshine/outdoor application.
- Material:UL approved nylon 11/12
- Color:Black
- Package:100pcs/bag
- Unit:mm(inch)
- 特点:耐候佳、不吸水、适用于户外
- 材质:尼龙11/12.
- 颜色: 黑
- 包装: 100个/包
- 单位: 毫米 (英寸).



Part No.	Approx.Length mm(inch)	Approx.Width mm(inch)	Thickness mm(inch)	Max.Bundle Dia. mm(inch)	Min.Loop Tensile Strength kg(lbs)	Recommend Crimping Tools
GNN-180HDB	180(7.09)	8.6(0.399)	2.0(0.079)	40(1.57)	35(77)	
GNN-260HDB	260(10.24)			53(2.09)	50(110)	
GNN-360HDB	355(13.98)			83(3.27)		

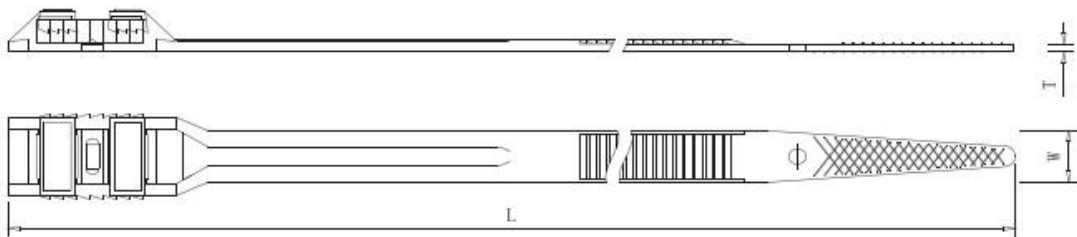

产品规格书

束线带系列 (Cable Tie Series)

▶ **MARKER TIE**

标示束线带

- Tie and identify bundles of cable in one operation.
- Flat areas may be imprinted or written with marker pen.
- Material: UL approved nylon 66 94V-2
- Color: All color available
- Package: 1000 or 100pcs/bag
- Unit: mm(inch)
- 特点: 固定捆绑电线, 并可同时标示电线 (以标示或书写方式皆可).
- 材质: 尼龙66, 防火等级94V-2.
- 颜色: 各种颜色皆可.
- 包装: 1000或100个/包
- 单位: 毫米(英寸).



E314653

Part No.		Approx.Length mm(inch)	Approx.Width mm(inch)	Max.Bundle Dia. mm(inch)	Min.Loop Tensile Strength kg(lbs)
1000pcs/bag	100pcs/bag				
GNK-100M	GNK-100MC	102(4.01)	2.5(0.10)	18(0.71)	8.1(18)
GNK-200M	GNK-200MC	200(7.87)		50(1.97)	

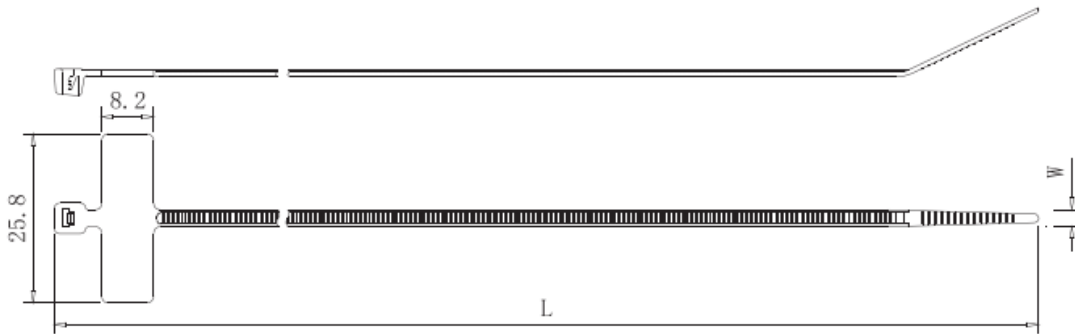

GNK-110M	GNK-110MC	112(4.39)	2.5(0.10)	18(0.71)	8.1(18)
GNK-210M	GNK-210MC	210(8.27)		50(1.97)	

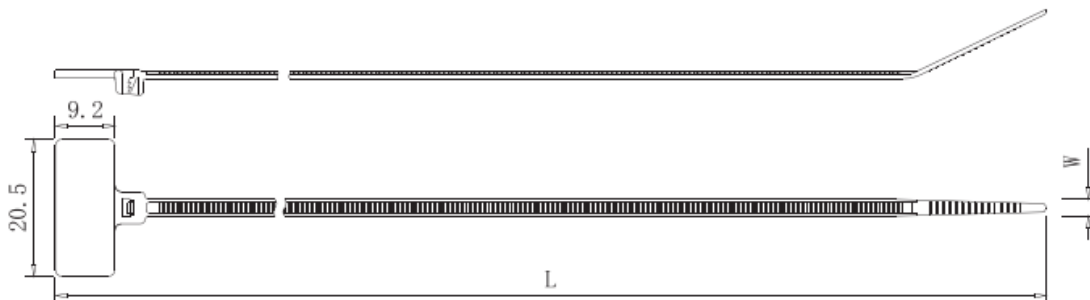

产品规格书

束线带系列 (Cable Tie Series)

► PUSH MOUNT TIE

插销式束线带

- Drill a hole on the panel, insert the tie to the hole for bundling wires.
- Material: UL approved Nylon 66, 94V-2
- Color: All color available
- Package: 1000 or 100pcs/bag
- Unit: mm(inch)
- 特点: 先将机板钻孔, 然后把扎带插入孔内, 再将电线束紧即可, 适合工业及一般家电产品之电源线捆绑及固定用.
- 材质: 尼龙66, 防火等级94V-2.
- 颜色: 各种颜色皆可.
- 包装: 1000或100个/包
- 单位: 毫米(英寸).



E314653

Part No.		Approx.Length mm(inch)	Approx.Width mm(inch)	Max.Bundle Dia. mm(inch)	Min.Loop Tensile Strength kg(lbs)	Hole Diameter mm(inch)	Panel Thickness mm(inch)
1000pcs/bag	100pcs/bag						
GNP-110M	GNP-110MC	110(4.33)	2.5(0.10)	28(1.10)	8.1(18)	Ø4.8(0.189)	~2.4(0.094)
GNP-130M	GNP-130MC	130(5.12)	2.5(0.10)	28(1.10)	8.1(18)	Ø4.8(0.189)	~2.4(0.094)

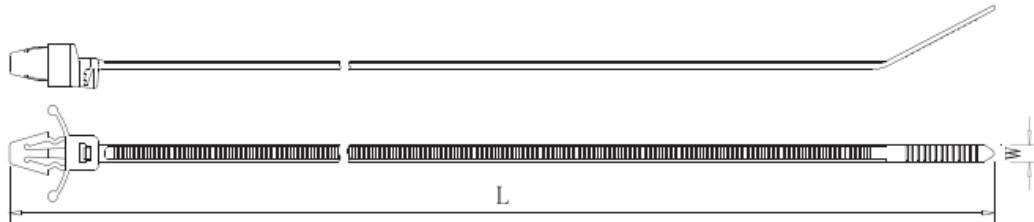

GNP-110MA	GNP-110MAC	110(4.33)	2.5(0.10)	28(1.10)	8.1(18)	Ø4.8(0.189)	~2.4(0.094)
-----------	------------	-----------	-----------	----------	---------	-------------	-------------

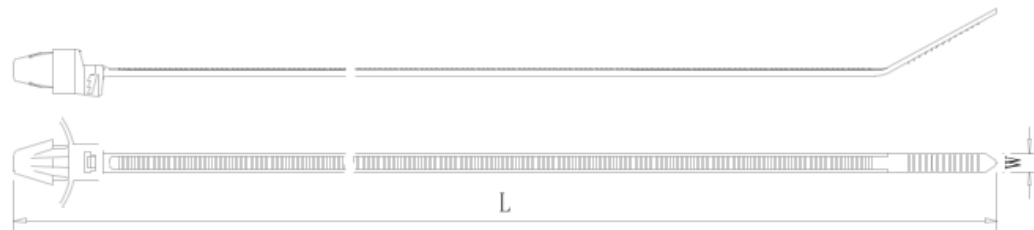

GNP-130I	GTP-130IC	130(5.12)	3.2(0.13)	28(1.10)	13.6(30)	Ø4.0(0.157)	~2.0(0.079)
GNP-130I	GNP-130IC	130(5.12)	3.2(0.13)	28(1.10)	13.6(30)	Ø5.2(0.205)	~2.8(0.110)
GNP-150I	GNP-150IC	150(5.91)	3.6(0.14)	32(1.26)	13.6(30)	Ø5.2(0.205)	~2.8(0.110)

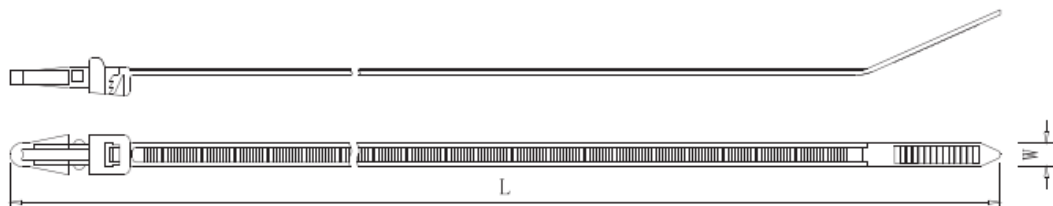

束线带系列 (Cable Tie Series)

Part No.		Approx. Length mm(inch)	Approx. Width mm(inch)	Max. Bundle Dia. mm(inch)	Min. Loop Tensile Strength kg(lbs)	Hole Diameter mm(inch)	Panel Thickness mm(inch)
1000pcs/bag	100pcs/bag						
GNP-130IA	GNP-130IAC	130(5.12)	3.2(0.13)	28(1.10)	13.6(30)	Ø4.0(0.157)	~2.0(0.079)

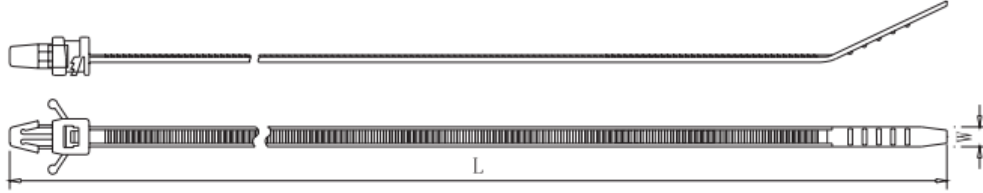

GNP-130ST	GNP-130STC	135(5.31)	4.8(0.19)	25(0.98)	22.2(50)	Ø6.4(0.252)	~3.2(0.126)
GNP-170ST	GNP-170STC	176(6.92)	4.8(0.19)	38(1.50)	22.2(50)	Ø6.4(0.252)	~3.2(0.126)
GNP-190ST	GNP-190STC	202(7.95)	4.8(0.19)	45(1.77)	22.2(50)	Ø6.4(0.252)	~3.2(0.126)

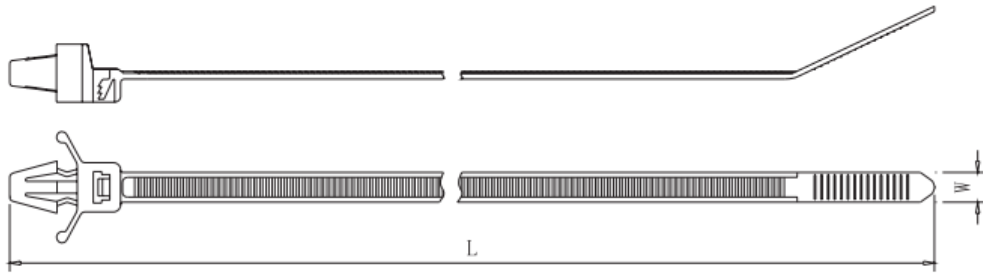

GNP-200ST	GNP-200STC	203(7.99)	4.8(0.19)	46(1.81)	22.2(50)	Ø6.3(0.248)	~3.6(0.141)
-----------	------------	-----------	-----------	----------	----------	-------------	-------------

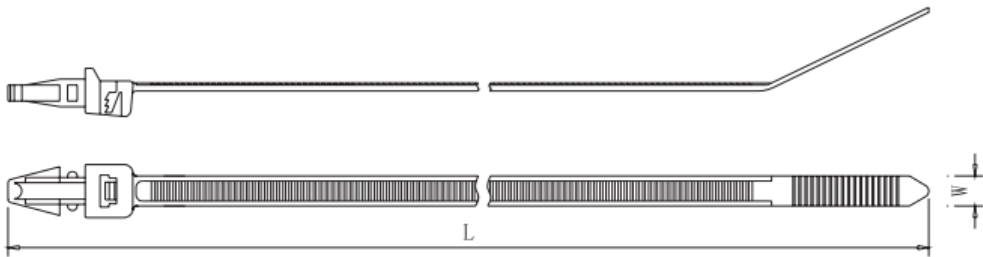

GGRP-130I	GGRP-130IC	130(5.12)	3.2(0.13)	28(1.1)	13.6(30)	Ø4.0(0.157)	~2.0(0.079)
-----------	------------	-----------	-----------	---------	----------	-------------	-------------

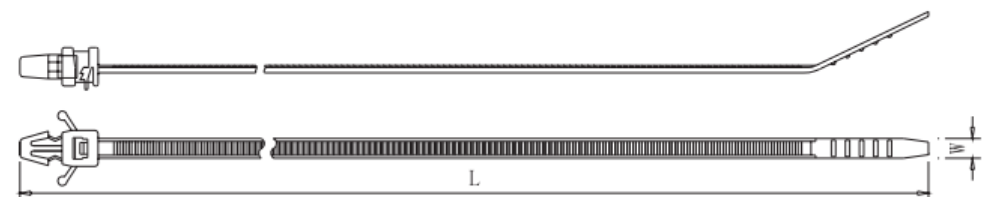

Part No.		Approx.Length mm(inch)	Approx.Width mm(inch)	Max.Bundle Dia. mm(inch)	Min.Loop Tensile Strength kg(lbs)	Hole Diameter mm(inch)	Panel Thickness mm(inch)
1000pcs/bag	100pcs/bag						
GGRP-110ST	GGRP-110STC	110(4.33)	4.8(0.19)	22(0.87)	22.2(50)	Ø6.4(0.252)	~3.2(0.126)
GGRP-190ST	GGRP-190STC	200(7.87)		45(1.77)		Ø6.4(0.252)	~3.2(0.126)

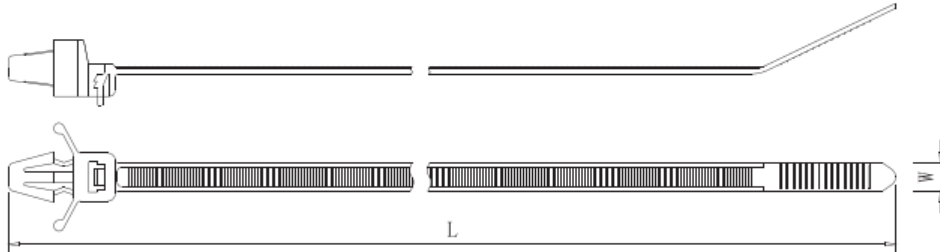

GGRP-200ST	GGRP-200STC	200(7.87)	4.8(0.19)	46(1.81)	22.2(50)	Ø6.3(0.248)	~3.6(0.141)
------------	-------------	-----------	-----------	----------	----------	-------------	-------------

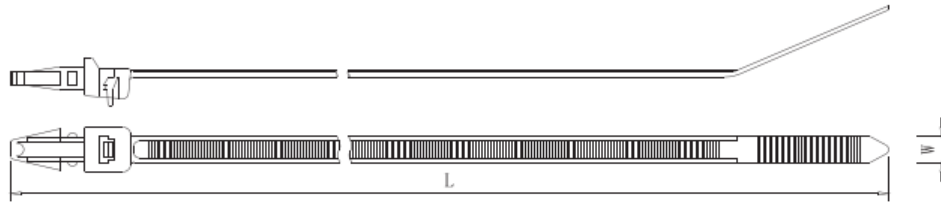

▶ PE TIE
▶ PE 带

- Application in garden, easy to install and release.
- Material: PE
- Color: All color available
- Package: 100pcs/bag
- Unit: mm(inch)
- 特点: 应用于园艺, 易重复组装使用.
- 材质: PE.
- 颜色: 各种颜色皆可.
- 包装: 100个/包
- 单位: 毫米(英寸).

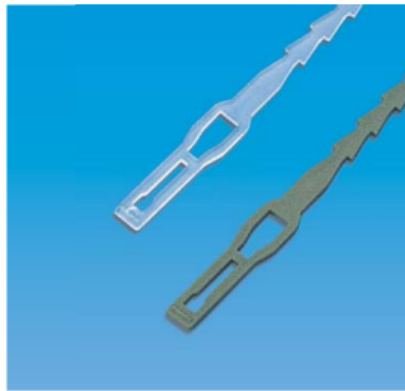

Part No.	Approx.Length mm(inch)	Approx.Width mm(inch)	Thickness mm(inch)
AST-115	112(4.41)	7.5(0.30)	4.5(0.18)
AST-173	167(6.57)	8.2(0.32)	5.2(0.20)

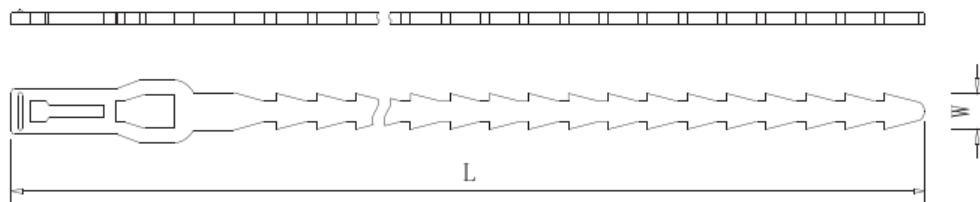

不锈钢嵌片锁紧尼龙扎带

Nylon Cable Ties- Barb-Lock Type



► 技术信息

- 产品材料: 尼龙66
- 嵌片材料: 不锈钢304
- 温度范围: -40°C ~ 85°C
- 产品颜色: 本色或者黑色
- 防火等级: UL94 V-2
- 其他特性: 无卤

► 产品特性

- 钢牙可以提供更持久的扎带性能, 稳定性更高, 调整度更大
- 高强度, 操作简单方便
- 带身上的点状结构可以防止捆绑后的滑动
- 尾部设计便于穿过扎带孔, 加快捆绑速度
- 产品高于行业标准的拉力强度
- 备有不同材料, 适用于多种产品用途和使用环境
- 适用条件: 户外或室内

► 特殊材质要求

- 燃烧等级可以达到UL94 V-0。
- 抗UV材质, 建议在室外使用。
- 高温热稳定性 (达到125°C), 适用于高温环境。
- 阻燃材质, 适用于公共交通线, 隧道等, 满足低烟低燃烧的要求。

► Technical Information

- Material-Tie: Nylon 66
- Material- Locking Barb: Stainless Steel Grade 304.
- Temperature Range: -40°C to 85°C
- Color: Nature or Black
- Flammability: UL94 V-2
- Other properties: Halogen Free

► Product Feature

- Stainless steel barb provides consistent performance and reliability and infinite adjustability through entire bundle range.
- High Strength and low thread force
- Stippled strap body prevents lateral movement on the bundle.
- Curved tip is easy to pick up from flat surfaces and allows faster initial threading to speed installation.
- High loop Strength exceeds industry standards.
- A variety of materials are available for specific applications.
- For indoor or outdoor use

► Available Special Requirements

- Flame retardant(UL94 V-0)
- UV Resistant, ideal for outdoor with lots of sunlight.
- Heat stabilized(up to +125°C). Ideal for environment with high temperature.
- Ideal for environment requires low flammability and low smoke, such as public transportation, tunnel, etc.

规格型号 Item No.	宽度 Width		长度 Length		厚度 Thickness		最大捆绑直径 Max. Bundle Dia.		最小捆绑直径 Min. Bundle Dia.		最小拉力 Min. Tensile Strength		安装工具 Hand Tool
	mm	inch	mm	inch	mm	inch	mm	inch	mm	inch	N	lbs	
NZQOD-2.4*102	2.4	0.094	102	4.02	0.9	0.035	23	0.91	2.0	0.079	80	18	LS-519
NZQOD-3.6*155	3.6	0.142	155	6.10	1.1	0.043	35	1.38	3.0	0.118	178	40	
NZQOD-3.6*203	3.6	0.142	203	7.99	1.1	0.043	51	2.01	3.0	0.118	178	40	
NZQOD-4.7*186	4.7	0.185	186	7.32	1.15	0.045	45	1.77	3.5	0.138	222	50	
NZQOD-4.7*203	4.7	0.185	203	7.99	1.15	0.045	50	1.97	3.5	0.138	222	50	
NZQOD-4.8*250	4.8	0.189	250	9.84	1.3	0.051	65	2.56	3.5	0.138	222	50	
NZQOD-4.8*305	4.8	0.189	305	12.01	1.25	0.049	82	3.23	3.5	0.138	222	50	
NZQOD-4.8*361	4.8	0.189	361	14.21	1.3	0.051	100	3.94	3.5	0.138	222	50	
NZQOD-4.8*376	4.8	0.189	376	14.80	1.45	0.057	105	2.01	3.5	0.138	222	50	
NZQOD-7*221	7.0	0.276	221	8.70	1.7	0.067	51	3.15	6.0	0.236	534	120	
NZQOD-7*300	7.0	0.276	300	11.81	1.7	0.067	80	4.02	6.0	0.236	534	120	
NZQOD-7*378	7.0	0.276	378	14.88	1.7	0.067	102	4.13	6.0	0.236	534	120	
NZQOD-7*699	7.0	0.276	699	27.52	1.7	0.067	203	7.99	6.0	0.236	534	120	
NZQOD-7*780	7.0	0.276	780	30.71	1.7	0.067	256	10.08	6.0	0.236	534	120	
NZQOC-8*240	8.0	0.315	240	9.45	1.6	0.063	57	2.24	9.0	0.354	450	100	
NZQOD-8*400	8.0	0.315	400	15.75	1.65	0.065	108	4.25	9.0	0.354	534	120	
NZQOC-10*300	10.0	0.394	300	11.81	1.6	0.063	77	3.03	14.0	0.551	550	124	
NZQOC-10*350	10.0	0.394	350	13.78	1.6	0.063	97	3.82	14.0	0.551	550	124	
NZQOC-10*400	10.0	0.394	400	15.75	1.6	0.063	109	4.29	14.0	0.551	550	124	
NZQOC-10*450	10.0	0.394	450	17.72	1.6	0.063	124	4.88	14.0	0.551	550	124	
NZQOD-10*600	10.0	0.394	600	23.62	1.6	0.063	197	7.76	14.0	0.551	550	124	

- 订购产品时，请用N表示尼龙本色，B表示黑色。

- Please add "N" for Nature, or "B" for Black Color.

▶ **GIT-701**

For tension and cut-off
cable tie from width 2.4mm
to 4.8mm
FOR "DIY" ONLY



GIT-701

▶ **GIT-701**

将束带拉紧并切断,适用束带
宽度为2.4mm~4.8mm,只适用
于"手动".

▶ **GIT-702P**

Blue.

For fast,safe tensioning and
cut off cable tie from width
2.4mm to 4.8mm
Material:Plastic



GIT-702P

▶ **GIT-702P**

蓝色

快速将束带拉紧并切断,适用束
带宽度为2.4mm~4.8mm.
材料:塑胶制

▶ **GIT-702M**

Metal,Red.

For fast,safe tensioning and cut
off cable tie from width2.4mm
to 4.8mm
Material:Metal



GIT-702M

▶ **GIT-702M**

红色.

快速将束带拉紧并切断,适用束带
宽度为2.4mm~4.8mm.
材料:金属制

▶ **GIT-705**

Function: For Stainless steel ties.
Fasten and automatic cut ties, with adjustable bundling pressure
Length: 178*140*29
Weight: 560g
Stainless steel tie:
Thickness up to 0.3mm
Width up to 7.9mm



GIT-705

▶ **GIT-705**

功能: 用于“不锈钢束带”快速将束带拉紧并切断, 且可调整扎捆时之压力。
长度: 178*140*29
重量: 560g
适用束带尺寸: 厚度可至 0.3mm, 宽度可至 7.9mm.

▶ **GIT-704**

Function: For cable tie thickness 1.3mm~2.3mm and width 3.6mm~9.5mm
Characteristics:
1. Completely made by press stamping.
2. Point of support in center, provide equidistance motion when tightening the cable tie.
3. Wider mouth suitable for wider cable tie.
4. With stopped guide to avoid hand clipped.
5. Single spring loaded, with comfortable hand force.
6. Length: 7 1/2 (190±3mm)
M.T.L: 1.5mm LOW CARBON STEEL



GIT-704

▶ **GIT-704**

功能: 可钳紧之厚度为 1.3mm~2.3mm, 宽度为 3.6mm~9.5mm 之缆绳。
特性:
1. 完全由压印机压制。
2. 尖端由中央支力, 于钳紧缆绳时提供等距之力。
3. 宽口处可适用于较宽缆绳钳控。
4. 附近有停止指引, 防止手部夹伤。
5. 附有弹簧, 使用舒适。
长度: 7 1/2 (190±3)
材料: 1.5 低碳钢

产品规格书

束线带系列 (Cable Tie Series)

ADHESIVE BACKED TIE MOUNT 粘式束线固定座

- Adhesive-backed, easy to peel off and mount on the flat place.
- Cable tie can be insert to fix wires.
- Material: UL approved nylon 66 94V-2
- Color: All color available
- package: 1000 or 100pcs/bag
- Unit: mm (inch)
- 特点: 撕开背胶即可固定于平板上, 再以束带穿入即可作固定用, GN-3A、4A亦可使用螺丝加强固定.
- 材质: 尼龙66, 防火等级94V-2.
- 颜色: 各种颜色皆可.
- 包装: 1000或100个/包
- 单位: 毫米(英寸).



Part No. GN-4A

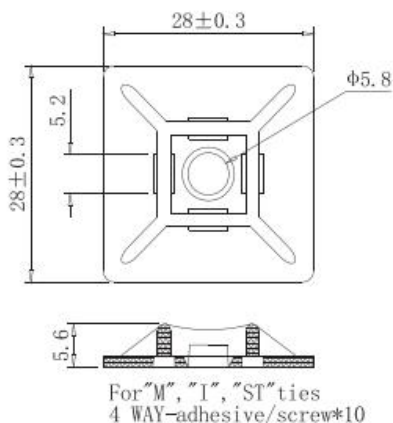

Part No. GN-3A

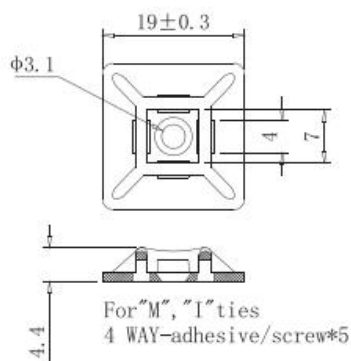

Part No. GN-2A

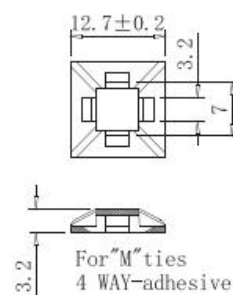

CABLE CLAMP 二段式配线固定座

- Backed with high-quality adhesive for fix wires.
- Material: UL approved nylon 66 94V-2
- Color: All color available
- Unit: mm (inch)
- Package: 100pcs/bag
- 特点: 背胶式, 可快速拆卸, 固定电线.
- 材质: 尼龙66, 防火等级94V-2.
- 颜色: 各种颜色皆可.
- 单位: 毫米(英寸).
- 包装: 100个/包

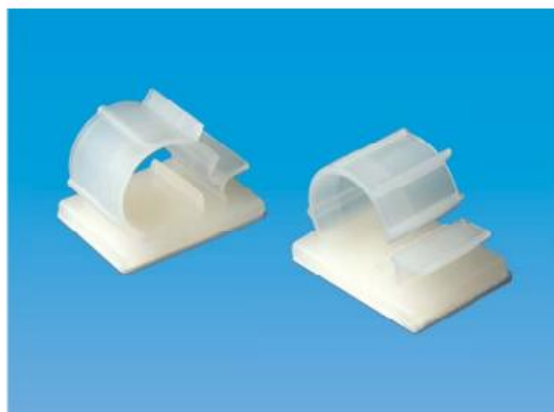

Part No. GN-10A

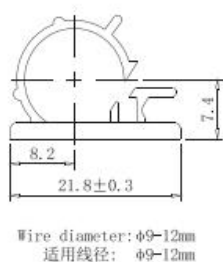

Part No. GN-11A

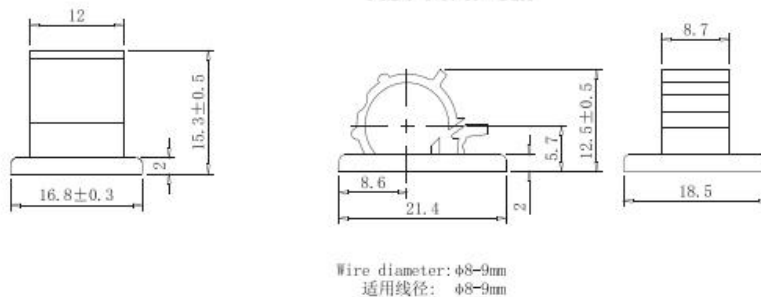

产品规格书

束线带系列 (Cable Tie Series)

▶ SADDLE TIE MOUNT

扎线固定座

- Screw applied. Unique cradle design provides maximum stability and rigidity to wire bundle.
- Material: UL approved nylon 66 94V-2
- Color: All color available
- Package: 1000 or 100pcs/bag
- Unit: mm (inch)
- 适用螺丝、马鞍型设计使电线易于固定。
- 材质: 尼龙66, 防火等级94V-2.
- 颜色: 各种颜色皆可。
- 包装: 1000或100个/包
- 单位: 毫米(英寸).



Part No.		Mounting Method	Dimension					Suitable ties
1000pcs/bag	100pcs/bag		A	B	C	D	E	
TM-2S6	TM-2S6C	#6 Screw	14.9(0.587)	9.5(0.374)	7.0(0.276)	3.7(0.146)	7.0(0.276)	"ST" ties
TM-2S8	TM-2S8C	#8 Screw	14.9(0.587)	9.5(0.374)	7.0(0.276)	4.5(0.177)	7.8(0.307)	
TM-3S8	TM-3S8C	#8 Screw	21.2(0.835)	15.3(0.602)	9.4(0.370)	4.5(0.177)	8.0(0.315)	"HD" ties
TM-3S10	TM-3S10C	#10 Screw	21.2(0.835)	15.3(0.602)	9.4(0.370)	5.0(0.197)	10.8(0.425)	
TM-3S25	TM-3S25C	1/4" Screw	21.9(0.862)	15.9(0.626)	9.4(0.370)	6.5(0.256)	12.8(0.504)	

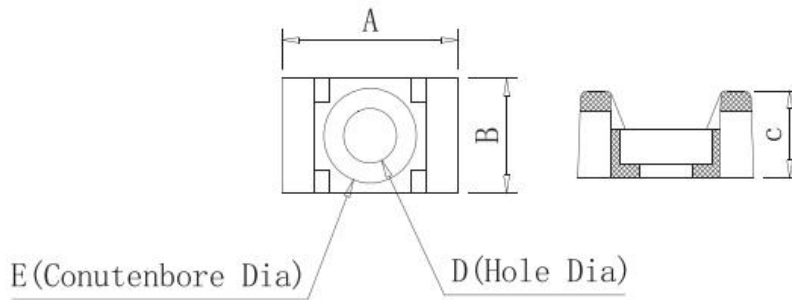

产品规格书

束线带系列 (Cable Tie Series)

► SCREW APPLIED LOW PROFILE MOUNT

可锁式扎线固定座

- Designed to secure wire bundles in applications where space is limited.
- Material: nylon 66 94V-2
- Color: All color available
- Package: 1000 or 100pcs/bag
- Unit: mm (inch)
- 此设计适用于在有限的空间里固定整束电线。
- 材质: 尼龙66, 防火等级94V-2.
- 颜色: 各种颜色皆可.
- 包装: 1000或100个/包
- 单位: 毫米(英寸).



Part No.		Mounting Method	Dimension				Suitable ties
1000pcs/bag	100pcs/bag		A	B	C	D	
SM-5	SM-5C	#5 Screw	10.2(0.40)	8.1(0.32)	2.5(0.10)	3.5(0.138)	"M" ties
SM-8	SM-8C	#8 Screw	18.9(0.744)	12.7(0.50)	3.0(0.12)	4.4(0.173)	"ST" ties

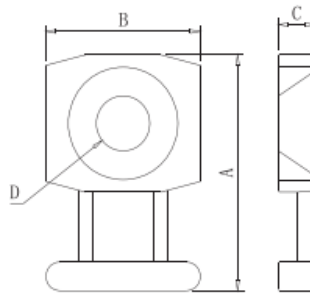

► CABLE TIE HOLDER

束线固定座

- For wall plug Ø8 hole diameter. cable tie can be inserted to secure wire bundles .
- Material: UL approved nylon 66 94V-2
- Color: All color available
- Package: 100pcs/bag
- Unit: mm (inch)
- 特点: 可固定于墙壁, 与束线带配合使用, 此设计适用于孔径Ø8
- 材质: 尼龙66, 防火等级94V-2
- 颜色: 各种颜色皆可.
- 包装: 100个/包
- 单位: 毫米(英寸).

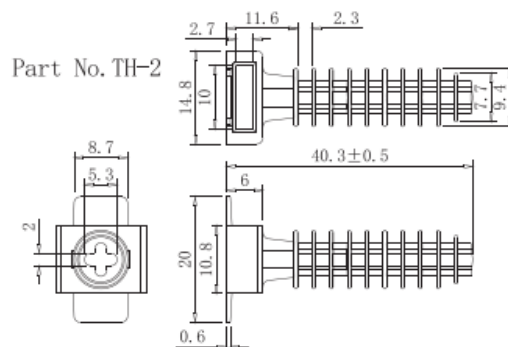
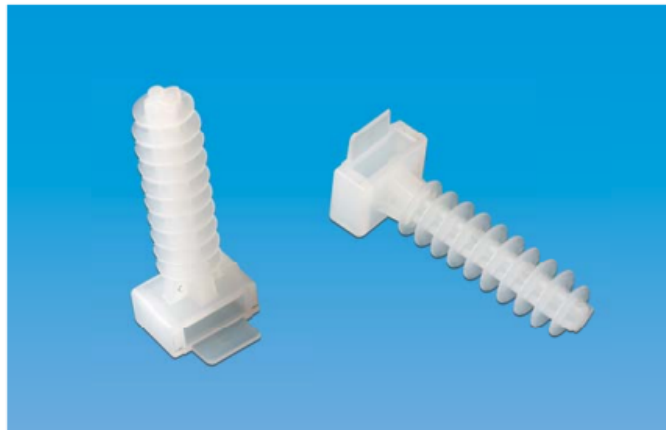

产品规格书

束线带系列 (Cable Tie Series)

CABLE CLAMP

配线固定夹

- Set cables in, clamp by screw.
- Material: UL approved 66, 94V-2
- Color: All color available
- Package: 1000 or 100pcs/bag
- Unit: mm(inch)
- 使用方法: 将电缆置于固定扣内, 再以螺丝固定
- 材质: 尼龙66, 防火等级94V-2.
- 颜色: 各种颜色皆可.
- 包装: 1000或100个/包
- 单位: 毫米(英寸).



Part No.		Dimension					
1000pcs/bag	100pcs/bag	Ømm(inch)	Ømm(inch)	A / mm(inch)	B+0.3mm(inch)	C / mm(inch)	D+0.2/Screw Dim
GCL-1/8S	GCL-1/8SC	Ø3.6(0.142)	3.3(0.130)	8.2(0.323)	9.1(0.358)	1.27(0.050)	Ø5.45 for M5
GCL-3/16S	GCL-3/16SC	Ø5.3(0.209)	4.8(0.189)	9.6(0.378)	9.1(0.358)	1.27(0.050)	Ø5.45 for M5
GCL-1/4S	GCL-1/4SC	Ø7.4(0.291)	6.6(0.260)	10.3(0.406)	9.1(0.358)	1.27(0.050)	Ø5.45 for M5
GCL-5/16S	GCL-5/16SC	Ø8.9(0.350)	7.8(0.307)	10.6(0.417)	9.1(0.358)	1.27(0.050)	Ø5.45 for M5
GCL-3/8S	GCL-3/8SC	Ø10.9(0.429)	9.7(0.382)	11.9(0.469)	9.2(0.362)	1.27(0.050)	Ø5.45 for M5
GCL-1/8	GCL-1/8C	Ø3.1(0.122)	2.9(0.114)	9.1(0.358)	12.7(0.500)	1.5(0.059)	Ø5.4 for M5
GCL-1/4	GCL-1/4C	Ø6.3(0.248)	5.9(0.232)	11.4(0.449)	12.7(0.500)	1.5(0.059)	Ø5.3 for M5
GCL-3/8	GCL-3/8C	Ø9.5(0.374)	9.1(0.358)	13.4(0.528)	12.1(0.476)	1.5(0.059)	Ø5.3 for M5
GCL-1/2	GCL-1/2C	Ø12.7(0.500)	12.2(0.480)	15.0(0.591)	12.7(0.500)	1.5(0.059)	Ø5.3 for M5
GCL-9/16	GCL-9/16C	Ø14.2(0.599)	13.8(0.543)	15.8(0.622)	12.7(0.500)	1.5(0.059)	Ø5.3 for M5
GCL-3/4	GCL-3/4C	Ø19.0(0.748)	18.6(0.732)	19.8(0.780)	12.7(0.500)	1.5(0.059)	Ø5.3 for M5
GCL-7/8	GCL-7/8C	Ø22.2(0.874)	21.8(0.858)	21.4(0.843)	12.7(0.500)	1.5(0.059)	Ø5.3 for M5
GCL-1-1/8	GCL-1-1/8C	Ø28.5(1.122)	27.9(1.098)	24.6(0.969)	12.7(0.500)	1.5(0.059)	Ø5.3 for M5
GCL-5/16L	GCL-5/16LC	Ø7.9(0.311)	7.6(0.3)	10.6(0.417)	12.7(0.500)	1.27(0.050)	Ø4.4 for M4

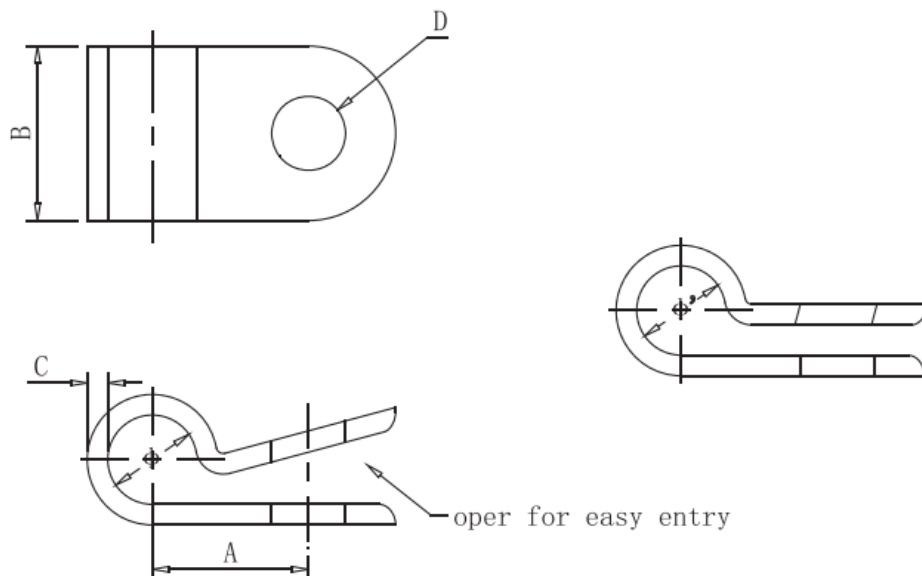

TWIST LOCK

扣式扭线环

- Strong adhesion for quick and easy installation.
- Reusable and releasable for easy wire bundling.
- Easy open-and-twist fit to cables.
- Color: All color available
- Material: Nylon 66
- Unit:mm(inch)
- Package:100pcs/bag
- 特点:强背胶固定电线,可重复使用,快速拆结
- 颜色:各种颜色皆可.
- 材质:尼龙66.
- 单位:毫米(英寸).
- 包装:100个/包



Part No.	Dimension					
	A±0.5	B±0.5	C±0.2	D±0.2	E±0.2	F±0.3
GN-8Aa	Ø8.6(0.339)	24.12(0.950)	17(0.699)	8(0.315)	2(0.079)	Ø5.4(0.213)
GN-8Ab	Ø16(0.699)	32(1.260)	20(0.787)	11.7(0.461)	2(0.079)	Ø5.8(0.228)

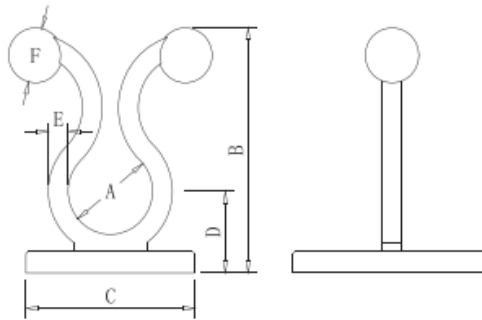

TWIST LOCK

扣式扭线环

- Reusable and releasable for easy wire bundling.
- Easy open-and-twist to cables.
- Material:UL approved nylon 66 94V-2
- Color: All color available
- Unit:mm(inch)
- Package:1000pcs/bag
- 特点:可重复使用,快速拆结
- 材质:尼龙66,防火等级94V-2.
- 颜色:各种颜色皆可.
- 单位:毫米(英寸).
- 包装:1000个/包

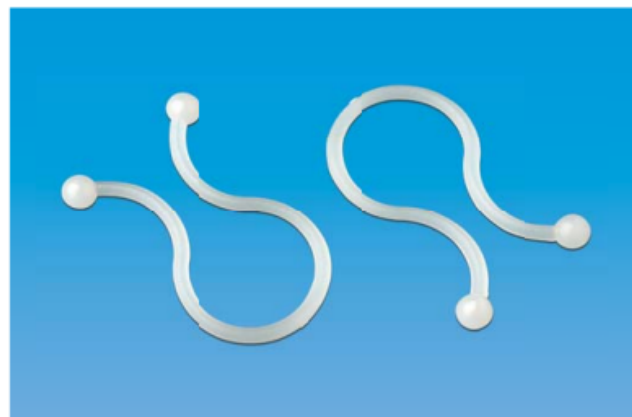

Part No.	Dimension		Bundle Dia
	A	B	
TH-D	11.2	28.4	~10.2
TH-E	5.2	21.0	~4.5
TH-F	8.3	25.2	~7.3
TH-G	11.5	30.9	~10.5
TH-H	15.0	35.1	~14.0
TH-I	18.0	40.0	~17.0
TH-J	19.5	42.5	~19.0
TH-K	22.5	45.5	~22.0
TH-L	5.2	22.0	~5.0

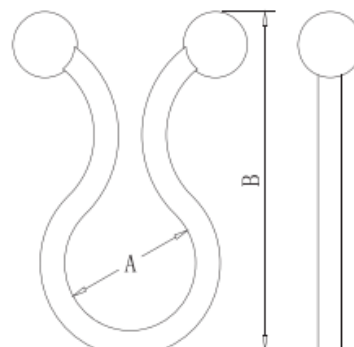

► **TWIST HOLDER**
隔离扭线环

- To separate wires from the board for avoiding hot components' interference.
- Cable and wire bundles load and unload with a fingertip twist.
- Material:UL approved nylon 66 94V-2
- Color: All color available
- Mounting hole diameter: $\varnothing 4.8 \pm 0.1 \text{mm}$
- Package:1000 or 100pcs/bag
- Unit:mm(inch)
- 将线路与PC板隔开,以隔绝发热零件之干扰,只需扭转两珠圆,即可扣住或松开整束电线.
- 材质:尼龙66,防火等级94V-2.
- 颜色:各种颜色皆可.
- 孔径: $\varnothing 4.8 \pm 0.1 \text{mm}$
- 包装:1000或100个/包
- 单位:毫米(英寸).
- 包装:1000或100个/包

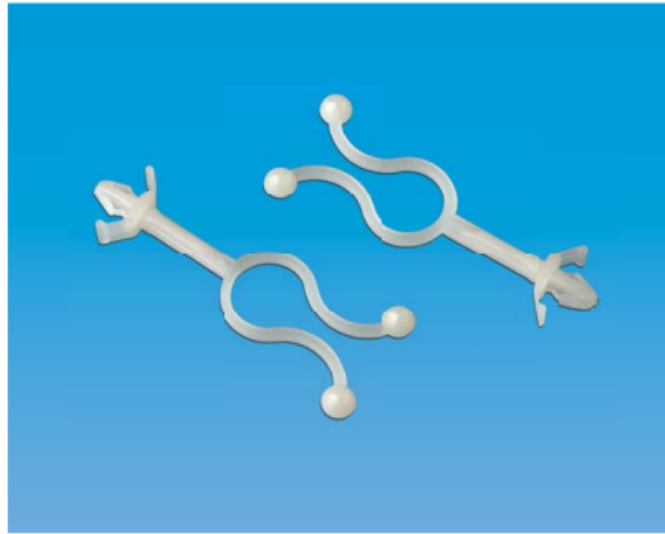

Part No.	Dimension				
	A	B	C	D	E
TH-A	28	21	12	7.5	4.8
TH-B	19.4	33.5	6		
TH-C	28.1	2.6	11		
TH-B1	20.5	5.0	6		

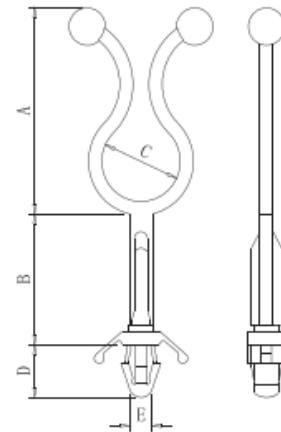

► **WIRE CLAMP**
配线固定扭

- Fix cables on the board.can be adjusted in any directions and angles.
- Material:UL approved nylon 66 94V-2
- Color: All color available
- Hole diameter in chassis: $\varnothing 4.8 \pm 0.1 \text{mm}$
- Panel thickness:1.6mm
- Unit:mm(inch)
- Package:1000pcs/bag
- 特点:固定电线于机板上,可做任何方向与角度的调整.
- 材质:尼龙66,防火等级94V-2
- 颜色:各种颜色皆可.
- 机板孔径: $\varnothing 4.8 \pm 0.1 \text{mm}$
- 板厚:1.6mm
- 单位:毫米(英寸).
- 包装:1000个/包

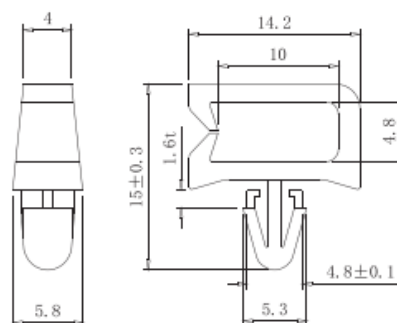

Part No. WH-A

► **SQ WIRE HOLDER**

马鞍型夹线套

- To secure precise routing.
- Lifts wires off board to avoid hot components and minimize transient interference.
- Material: UL approved nylon 66 94V-2
- Color: All color available
- package: 1000 or 100pcs/bag
- Mounting hold diameter : $\varnothing 4.8 \pm 0.1 \text{mm}$
- Unit: mm(inch)
- 精确的固定住线路.
- 将线路与PC板隔开,以隔绝发热零件之干扰.
- 材质: 尼龙66,防火等级94V-2
- 颜色: 各种颜色皆可.
- 包装: 1000或100个/包
- 孔径: $\varnothing 4.8 \pm 0.1 \text{mm}$
- 单位: 毫米(英寸)



Part No.	Dimension	
	A ± 0.3	B
CH-A	18	8.8
CH-B	27	17.5
CH-C	35	26

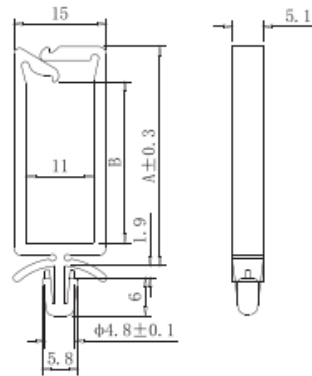

Part No.	Dimension	
	A ± 0.3	B
SH-A	13.2	4.8
SH-B	18.4	9.8
SH-C	27.2	19.0
SH-D	35.2	26.9

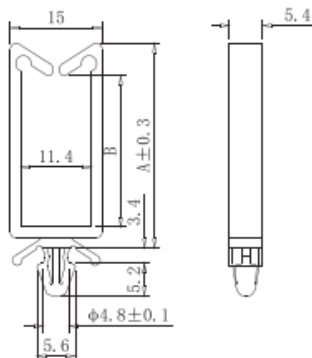

Part No.	Dimension	
	A ± 0.3	B
SQ-A	13.1	4.8
SQ-B	18.1	10
SQ-C	27.1	19
SQ-D	35.3	27

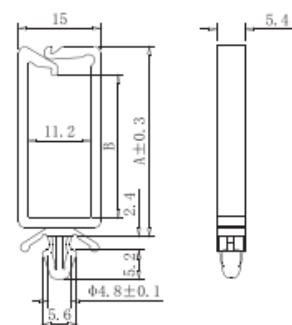

产品规格书

束线带系列 (Cable Tie Series)

► DUAL LOCKING PRINTED CIRCUIT BOARD SUPPORTS

P . C . B . 隔 离 柱

- Installed easily and quickly by hand.
- Barbed arrow mounts on both ends locking securely
- This support can be shaped to lock in the board for PCB/PCB or PCB/CHASSIS spacer
- Material:UL approved nylon 66 94V-2
- Color: All color available
- package:1000 or 100pcs/bag
- Unit:mm(inch)
- 安装容易、不费时
- 双边式倒钩式设计，可牢牢地锁上。
- 此设计可将PC板及电路板固定
- 材质:尼龙66,防火等级94V-2
- 颜色:各种颜色皆可。
- 包装:1000或100个/包
- 单位: 毫米(英寸).



Part No.	Spacing Height "A"±0.3mm(inch)
CBS-5A	4.6(0.181)
CBS-6A	6.2(0.244)
CBS-9A	9.2(0.362)
CBS-13A	12.6(0.496)
CBS-16A	15.8(0.622)
CBS-19A	19.1(0.752)
CBS-22A	22.2(0.874)
CBS-25A	25.3(0.996)
CBS-29A	28.6(1.126)
CBS-35A	33.3(1.311)

Hole dia:φ4.8±0.1mm(φ.189)
pane thickness:
0.5mm(.02) to 2.3mm(.091)

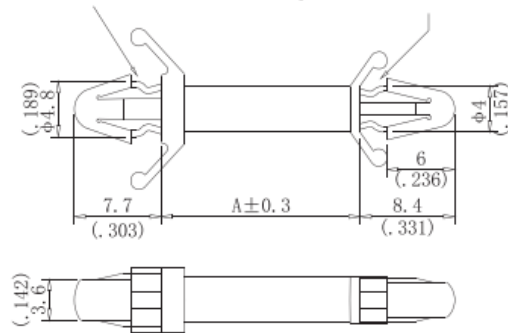

Part No.	Spacing Height "A"±0.3mm(inch)
CBS-6K	6.3(0.248)
CBS-8K	7.8(0.307)
CBS-9K	9.3(0.366)
CBS-12K	11.7(0.461)
CBS-13K	12.6(0.496)
CBS-16K	15.7(0.618)
CBS-19K	19.1(0.752)
CBS-22K	22.1(0.870)
CBS-25K	25.1(0.988)
CBS-29K	28.5(1.122)
CBS-35K	35.0(1.378)

NEW TYPE 新型

None tool are required in installation.

Re-usable.

Pinch head are easily plugged in and pulled out.

•Material:UL approved nylon 66 94V-2

Unit:mm (inch)

Package:1000 or 100pcs/bag

安装时不须任何工具

可重复使用

夹头设计,装卸容易

•材质:尼龙66,防火等级94V-2

•单位: 毫米(英寸).

•包装:1000 or 100个/包

Hole dia:φ4.8±0.1mm(φ.189)

pane thickness:
0.5mm(.02) to 2.3mm(.091)

Hole dia:φ4±0.1mm(φ.157)

Max thickness:2mm(.079)

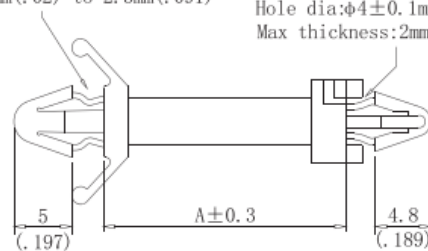
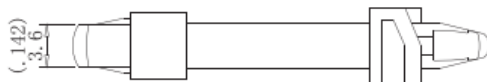

产品规格书

束线带系列 (Cable Tie Series)

▶ SPACER SUPPORT

▶ P. C. B 间隔柱

- Material: Nylon 66 94V-2
- Mounting hole diameter : $\varnothing 4.8 \pm 0.1 \text{mm} (\varnothing 190)$
- Panel thickness: $0.5(0.02) \sim 2.3(0.91)$
- Material: UL approved nylon 66 94V-2
- Color: All color available
- Package: 1000 or 100pcs/bag
- Unit: mm(inch)
- 孔径: $\varnothing 4.8 \pm 0.1 \text{mm} (\varnothing 190)$
- 板厚: $0.5(0.02) \sim 2.3(0.91)$
- 材质: 尼龙66, 防火等级94V-2
- 颜色: 各种颜色皆可.
- 包装: 1000或100个/包
- 单位: 毫米(英寸).



Part No.	Spacing Height "A" $\pm 0.3 \text{mm} (\text{inch})$
CBS-5P	4.7(0.185)
CBS-6P	6.3(0.248)
CBS-9P	9.3(0.366)
CBS-13P	12.6(0.496)
CBS-16P	15.9(0.626)
CBS-19P	19.0(0.748)
CBS-22P	22.2(0.874)
CBS-25P	25.2(0.992)
CBS-29P	28.6(1.126)
CBS-35P	33.4(1.315)

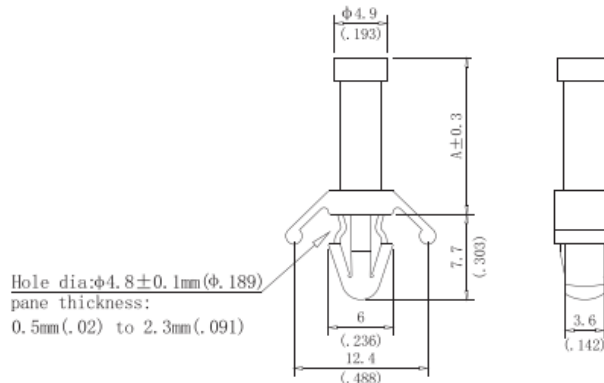

▶ REVERSE LOCKING CIRCUIT BOARD SUPPORT

▶ P . C . B 间隔柱

- Hole or slots needed on board can support for heavily loaded PC board.
- Minimum protrusion under chassis.
- Material: UL approved nylon 66 94V-2
- Color: All color available
- Package: 1000 or 100pcs/bag
- Unit: mm(inch)
- 可使用于负荷较重的PC板.
- 底板下突出空间少
- 材质: 尼龙66, 防火等级94V-2
- 颜色: 各种颜色皆可.
- 包装: 1000或100个/包
- 单位: 毫米(英寸).



Part No.	Dimension				
	$\varnothing A$	$\varnothing B$	$\varnothing C$	D	E
CBS-6B	7	5	11.5	6	1.6
CBS-10RA	7	5	10.4	7	1.5

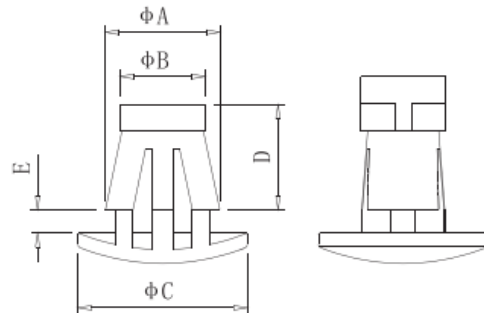

产品规格书

束线带系列 (Cable Tie Series)

▶ REVERSE LOCKING PRINTED CIRCUIT BOARD SUPPORT P . C . B . 间 隔 柱

- Thin button head For minimum protrusion
- Sharp head can provide vibration and shake.
- Insert the support through both holes from chassis underside.
- Material:UL approved nylon 66 94V-2
- Color: All color available
- Package:1000 or 100pcs/bag
- Unit:mm(inch)
- 手动安装,不须任何工具.
- 透过板上的孔插入
- 小型凸出的细头按钮可节省空间
- 材质:尼龙66,防火等级94V-2
- 颜色:各种颜色皆可.
- 包装:1000或100个/包
- 单位:毫米(英寸).



Part No.	Spacing Height "A"±0.3mm(inch)
CBS-6R	5.8(0.228)
CBS-7R	6.8(0.268)
CBS-8R	8.0(0.315)
CBS-10R	10.0(0.394)
CBS-12R	12.0(0.472)
CBS-14R	14.0(0.551)
CBS-16R	16.0(0.630)
CBS-18R	18.0(0.709)

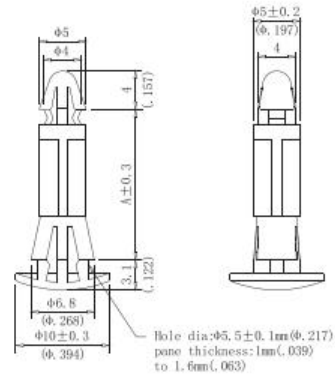

▶ REVERSE LOCKING PRINTED CIRCUIT BOARD SUPPORT P . C . B . 间 隔 柱

- Hole or slots needed on board can support for heavily loaded PC Board.
- Minimum protrusion under chassis.
- Material:UL approved nylon 66 94V-2
- Color: All color available
- Package:1000 or 100pcs/bag
- Unit:mm(inch)
- 可使用于负荷较重的PC板
- 底板下突出空间少
- 材质:尼龙66,防火等级94V-2
- 颜色:各种颜色皆可.
- 包装:1000或100个/包
- 单位:毫米(英寸).

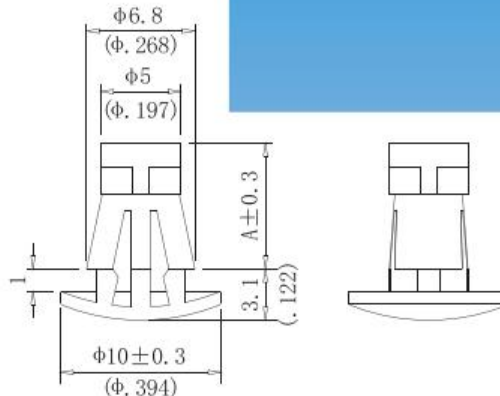

Part No.	Spacing Height "A"±0.3mm(inch)
CBS-6RS	5.8(0.228)
CBS-7RS	6.8(0.268)
CBS-8RS	8.0(0.315)
CBS-10RS	10.0(0.394)
CBS-12RS	12.0(0.472)
CBS-14RS	14.0(0.551)
CBS-16RS	16.0(0.630)
CBS-18RS	18.0(0.709)

▶ **ADHESIVE BACKED BOARD SUPPORT**
▶ **P.C.B. 隔离柱**

- Easy mounting with adhesive tape.
- For PCB of 1.6mm (0.063) thick as well as 2mm (0.079) thick.
- Material: UL approved nylon 66 94V-2
- Color: All color available
- Mounting hole diameter: $\varnothing 4 \pm 0.1 \text{mm} (0.157)$
- Unit: mm (inch)
- Package: 100 pcs/bag
- 撕开背胶即可固定.
- 适用于1.6mm (0.063)-2mm (0.079)之PC板厚度
- 材质: 尼龙66, 防火等级94V-2.
- 颜色: 各种颜色皆可.
- 孔径: $\varnothing 4 \pm 0.1 \text{mm} (0.157)$
- 单位: 毫米(英寸).
- 包装: 100个/包



Part No.	Spacing Height "A" $\pm 0.3 \text{mm} (\text{inch})$	B	C
ACBS-6M	5.6 (0.220)	18.0 (0.709)	2 (0.079)
ACBS-9M	8.7 (0.343)		
ACBS-12M	11.9 (0.469)		

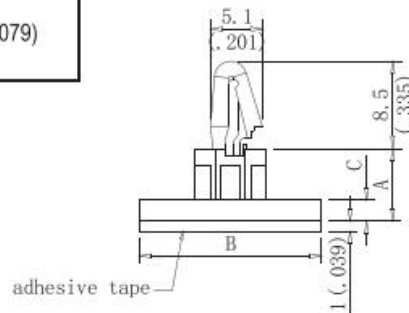
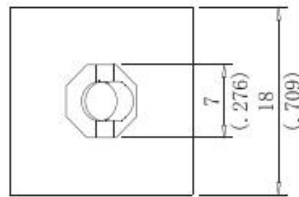

▶ **SCREW FASTENED LOCKING CIRCUIT**
▶ **P.C.B. 隔离柱**

- Support with minimum chassis protrusion serves for limited space or slim line applications.
- Head locks in boards, can be released by hand.
- Screw locks support; steady and firm.
- Material: UL approved nylon 66 94V-2
- Color: All color available
- Unit: mm (inch)
- Package: 1000 or 100 pcs/bag
- 可间隔小型机板.
- 扣住后, 可释放
- 将螺丝锁住, 很稳固
- 材质: 尼龙66, 防火等级94V-2.
- 颜色: 各种颜色皆可.
- 单位: 毫米(英寸).
- 包装: 1000或100个/包



Part No.	Spacing Height "A" $\pm 0.3 \text{mm} (\text{inch})$
CBS-6S	6.5 (0.256)
CBS-9S	9.6 (0.378)
CBS-13S	12.9 (0.508)
CBS-16S	16 (0.630)
CBS-19S	19.3 (0.760)
CBS-22S	22.4 (0.882)
CBS-25S	25.5 (1.004)
CBS-29S	29.0 (1.142)

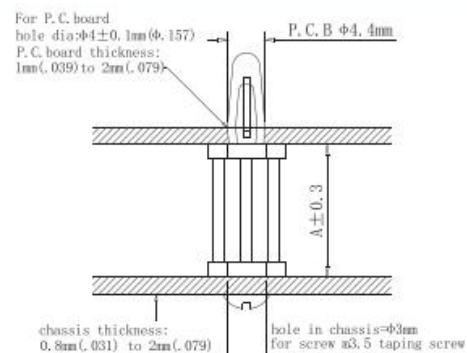

产品规格书

束线带系列 (Cable Tie Series)

▶ CIRCUIT BOARD SUPPORT POST BOARD SUPPORT

P . C . B . 间 隔 柱

- Easily installed by hand to lock securely .
- Easily removed by pinching prong tips.
- No tools are required.
- Material:UL approved nylon 66 94V-2
- Color: All color available
- Unit:mm (inch)
- Package:1000pcs/bag
- 易于安装及固定.
- 捏住尖头顶端即可移动.
- 无须任何工具.
- 材质:尼龙66,防火等级94V-2.
- 颜色:各种颜色皆可.
- 单位:毫米(英寸)
- 包装:1000或100个/包



Part No.	Spacing Height "A"±0.3mm(inch)
HSP-2N	3.2(0.126)
HSP-5N	4.8(0.189)
HSP-6N	6.3(0.248)
HSP-8N	7.9(0.311)
HSP-9N	9.4(0.370)
HSP-11N	11.3(0.445)
HSP-13N	12.7(0.500)
HSP-16N	15.9(0.626)
HSP-19N	19.1(0.752)
HSP-22N	22.2(0.874)

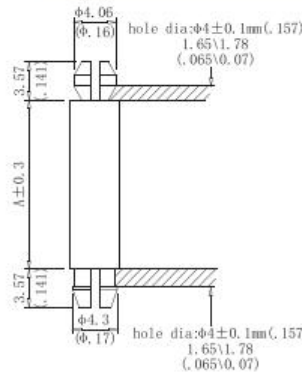

▶ DUAL LOCKING PRINTED CIRCUIT BOARD SUPPORT

P . C . B . 间 隔 柱

- Mini size saves space .
- Installed by hand with no screws.
- After board have supports installed the PCB Support hold them firmly in place.
- Snap together to stack more boards in unlimited space
- Material:UL approved nylon 66 94V-2
- Color: All color available
- Package:1000 pcs/bag
- Unit:mm(inch)
- 体积小、节省空间,手动安装,不须螺丝.
- 安装后,可固定住.
- 利用有限空间,可做PC板的堆积.
- 材质:尼龙66,防火等级94V-2.
- 颜色:各种颜色皆可.
- 单位:毫米(英寸).
- 包装:1000个/包



Part No.	Spacing Height	
	"A"±0.3mm(inch)	"B"±0.3mm(inch)
MCBS-7W	7.2(0.283)	14.2(0.559)
MCBS-9W	9.3(0.366)	16.2(0.638)
MCBS-11W	11.3(0.445)	18.2(0.717)
MCBS-13W	13.3(0.524)	20.2(0.795)

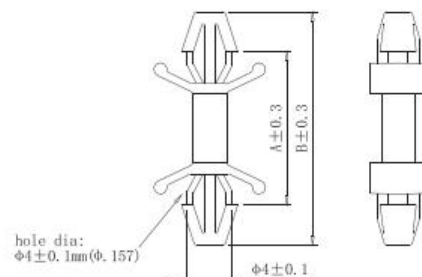

产品规格书

束线带系列 (Cable Tie Series)

MINI CARD SPACER SUPPORT P . C . B . 间隔柱

- Installed by hand no tools required.
- Insert the support through only one hole of board.
- Thin button head for minimum protrusion can save more space
- Material:UL approved nylon 66 94V-2
- Color: All color available
- Unit:mm (inch)
- Package:1000pcs/bag
- 手动安装,不须任何工具,透过板上的孔插入.
- 小型凸出的细头按钮可节省空间
- 材质:尼龙66,防火等级94V-2.
- 颜色:各种颜色皆可.
- 单位: 毫米(英寸).
- 包装:1000个/包



Part No.	Spacing Height "A"±0.3mm(inch)
MCBS-4P	4.1(0.161)
MCBS-6P	6.2(0.244)
MCBS-8P	8.2(0.323)
MCBS-10P	11.7(0.461)
MCBS-14P	14.3(0.563)

Hole dia:φ3±0.1mm(φ.118)
pane thickness:1.6mm(.063)

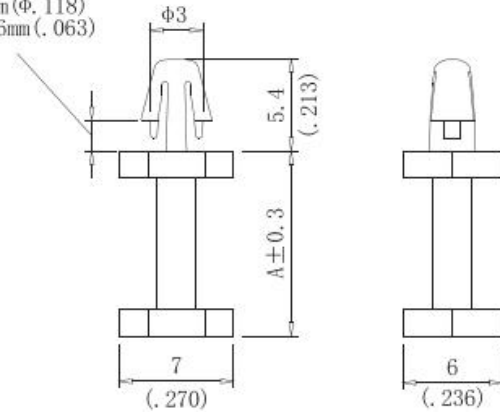

BUTTON TUBE 扣式套管

- Good for cable wrapping,protection.easy to wap , re-rsable.
- Button material:POM
- Material:Refractory a meshes mezzanine PVC
- Thickness:0.35mm
- Color:Black,gray
- Package:50M
- Unit:mm (inch)
- 整理并保护电缆,可快速组装与分解.
- 按钮材质:POM
- 厚度:0.35mm
- 颜色:黑、灰
- 包装:50M /包
- 单位: 毫米(英寸).

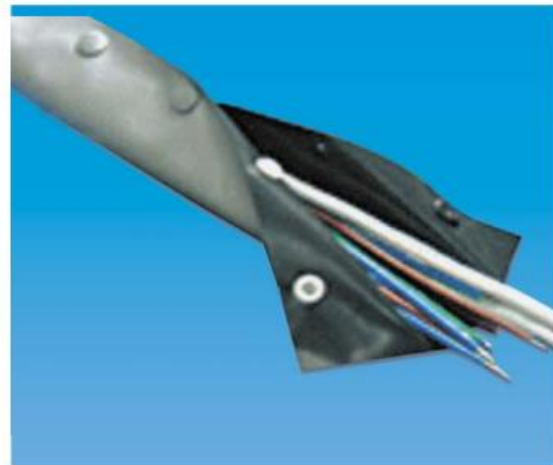

Part No.	Max Bundle Dia	Band Width
FBT-15	Ø15	75
FBT-20	Ø20	90
FBT-25	Ø25	100
FBT-30	Ø30	115
FBT-40	Ø40	146
FBT-50	Ø50	175
FBT-70	Ø70	241
FBT-100	Ø100	333

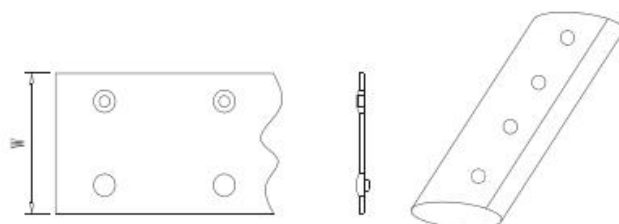

产品规格书

束线带系列 (Cable Tie Series)

▶ **MAGIC TUBE**

▶ 粘式套管

- Good for cable wrapping, protection. easy to wrap, re-usable.
- Material: Refractory meshes mezzanine PVC
- Velcro: Nylon
- Color: Black, gray
- Package: 25M
- Unit: mm (inch)
- 整理并保护电缆, 可快速组装与分解.
- 颜色: 黑、灰
- 包装: 25M / 包
- 单位: 毫米(英寸).

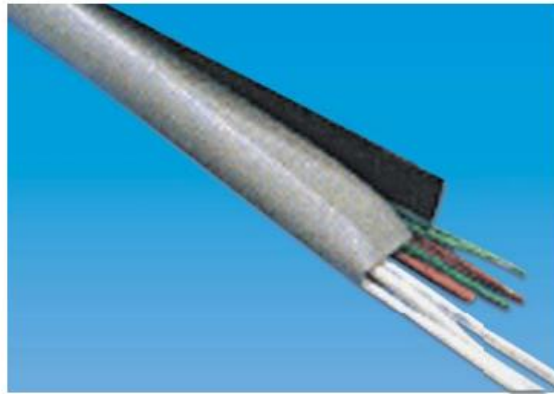

Part No.	Max Bundle Dia	Band Width
FMT-20	Ø20	90
FMT-25	Ø25	107
FMT-30	Ø30	123
FMT-40	Ø40	154
FMT-50	Ø50	185
FMT-70	Ø70	248
FMT-100	Ø100	342

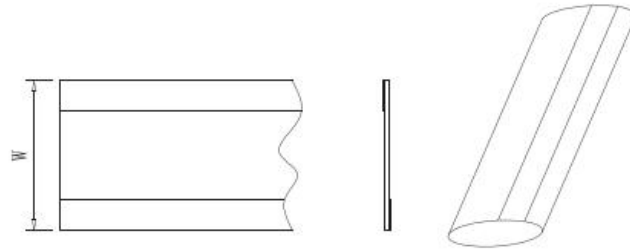

▶ **ALUMINUM FOIL BUTTON TUBE**

▶ 铝箔扣式套管

- Characteristics of resistance to magnetic wave interference.
- Thickness: 0.22mm
- Material: Flameproof aluminum foil PVC
- Operating temperature: -15°C to 50°C
- Color: Black
- Unit: mm (inch)
- 功能: 防磁波干扰特性.
- 材质: 耐燃铝箔PVC, 厚度0.22mm
- 适用温度: -15°C ~ 50°C
- 表面色: 黑
- 单位: 毫米(英寸).



Part No.	Max Bundle Dia	Band Width	Packing
FAB-10	Ø10	70	25M
FAB-15	Ø15	90	
FAB-20	Ø20	105	
FAB-25	Ø25	115	
FAB-30	Ø30	130	
FAB-40	Ø40	160	
FAB-50	Ø50	190	
FAB-70	Ø70	255	
FAB-100	Ø100	350	

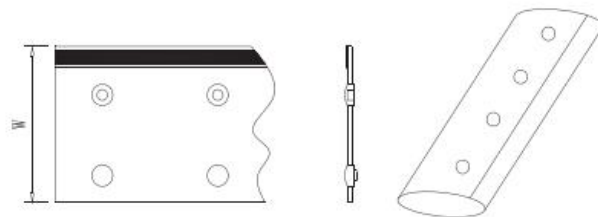

产品规格书

束线带系列 (Cable Tie Series)

▶ ALUMINUM FOIL BUTTON TUBE
▶ 铝箔粘式套管

- Characteristics of resistance to magnetic wave interference.
- Thickness:0.22mm
- Material:Flameproof aluminum foil PVC
- Operating temperature:-15°C to 50°C
- Color:Black
- Unit:mm (inch)
- 功能:防磁波干扰特性.
- 材质:耐燃铝箔PVC,厚度0.22mm
- 适用温度:-15°C ~ 50°C
- 表面色:黑
- 单位: 毫米(英寸).



Part No.	Max. Bundle Dia	Band Width	Packing
FAM-15	Ø15	15	25M
FAM-20	Ø20	20	
FAM-25	Ø25	25	
FAM-30	Ø30	30	
FAM-40	Ø40	40	
FAM-50	Ø50	50	

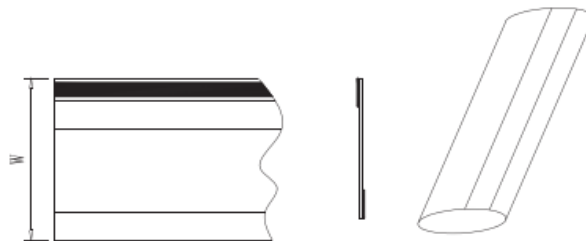

▶ CORD BUSHING
▶ 电源线扣

- The Cord Bushings are the easy low-cost way to insulate and protect your AC cords.
- Provide non-slip grip and will not injure insulation of AC cord
- Color: All color available
- 电源线扣是绝缘和保护AC电线即好用又廉价的商品.
- 咬紧后不滑动,且不会破坏AC电线的绝缘功能
- 颜色:各种颜色皆可.



Part No.	Type Gauge Wire Size	H	W	T	L
2B-2	SPT-1 18/2 20/2 2.8X5.58	9.9	8.8	3.20	10.30
3B-1	SPT-1 18/2 3.05X5.58	11.2	9.9	2.60	10.30
3B-2	STP-1 18/2 3.05X5.58	11.2	9.9	1.60	10.30
4B-2	SPT-1 18/2 3.05X5.58	12.7	11.3	2.60	11.50
4L-2	SPT-1 18/3 3.05X7.62	12.7	11.9	2.60	10.30
4W-2	SPT-2 & HPN 3.81X7.11	12.7	11.9	1.60	10.30
5B-2	18/2 16/2 6.35Ø-7.4Ø	12.7	11.45	2.60	11.10
5W-2	18/2 16/2 6.35Ø-7.4Ø	12.7	11.45	1.60	11.10
6B3-2S	8.25Ø-9.15Ø	15.9	14.00	3.20	14.70

Part No.	Type Gauge Wire Size	H	W	T	L
6B3-2R	8.25Ø-9.15Ø	15.9	14.00	3.20	14.70
6W3-4S	8.25Ø-9.15Ø	15.9	14.00	1.60	14.70
6W3-4R	8.25Ø-9.15Ø	15.9	14.00	1.60	14.70
7H-2	9.15Ø-11Ø	19.2	16.70	1.60	19.10
8H-2	13.46Ø-15.25Ø	22.2	21.20	3.20	20.50
3W-1	SPT-1 18/3	9.5/9.9	15.90	2.60	11.90
	3.05X7.62				
	SPT-2 18/3	10.5/10.7			
	3.81X10.16				
9H-2	#18 20-30PCS	19	19	1.60	18.80

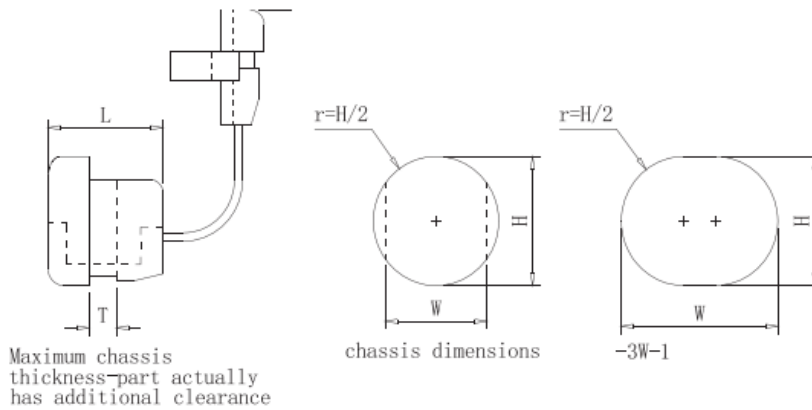

► CABLE CLIP

► n型电缆固定夹

- PE (grey)fixable,good elasticity,to bear collision,unable broken.
- Inserted nail,nail stick to plastic seat, save time and cost down
- Color: All color available
- package:100 or 50pcs/bag
- 本系列固定夹,均采PE(灰色)射出成型.
- 弹性大、耐冲击、绝不破裂
- 本系列固定夹,均为插钉式,钢钉直接附着于塑胶座上,可大量节省工时,降低施工成本.
- 颜色:各种颜色皆可.
- 包装:100或50个/包



Part No.	W	H	H1	Suitable Cables	Nails(mm)	Packing (pcs/bag)
GC-0.35	3.5	5.9	3.7	1 pair of wires	Ø2.0x15	100
GC-0.4	4	6.6	4.2	1 pair of wires	Ø2.5x18	100
GC-0.5	5.0	8.1	5.3	3C2V antenna;5 pair of wires	Ø2.5x18	100
GC-1	6.0	9.0	6.6	5C2V antenna;10 pair of wires	Ø2.5x20	100
GC-1.5	7	11	7.2		Ø2.5x22	100
GC-2	8.0	11.5	8.6	3C 1.25m ² wires	Ø2.5x22	100
GC-2.5	9	12	9		Ø2.5x25	100
GC-3	10.0	13.4	10.5	3C 3.5m ² wires; 3C 2m ² wires; 20 pair of wires	Ø2.5x27	100
GC-3.5	11.0	16.6	12.2	3C 3.5m ² wires; 2C 5.5m ² wires	Ø2.5x27	100
GC-4	12.0	16.0	12.5	2C 5.5m ² wires; 4C 5.5m ² wires ;3C 5.5m ² wires	Ø2.5x27	100
GC-6	14.0	20.5	15.6	3C 8m ² wires	Ø3.0x35	100
GC-7	16.0	21.7	17.0	3C 14m ² wires; 3 pipe(三分管)3/8" PVC pipe	Ø3.2x38	100

Part No.	W	H	H1	Suitable Cables	Nails(mm)	Packing (pcs/bag)
GC-7.2	18	22	17.5	3C 14m ² wires; 3 pipe(三分管)3/8" PVC pipe	Ø3.2x38	100
GC-7.5	20	23.5	18.5	3C 14m ² wires	Ø3.2x38	100
GC-8	22.0	27.8	22.5	3C 22m ² wires; 4 pipe(四分管)1/2" PVC pipe	Ø3.2x42	100
GC-9	25.0	31.6	26.0	3C 38m ² wires; 6 pipe(六分管)3/4" PVC pipe	Ø3.2x47	100
GC-10	32.0	40.0	33.5	1 inch pipe; 1" PVC pipe	Ø3.6x56	50

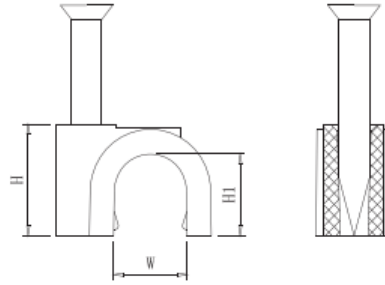

NAIL CABLE CLIP

钩型电缆固定夹

- PE ,fixable,good elasticity,to bear collision,unable broken.
- Inserted nail,nail stick to plastic seat,save time and cost down
- Color: All color available
- Packing:100pcs/bag
- 本系列固定夹,均采PE射出成型 弹性大、耐冲击、绝不破裂
- 本系列固定夹,均为插钉式,钢钉直接附着于 塑胶座上,可大量节省工时,降低施工成本.
- 颜色:各种颜色皆可.
- 包装:100个/包



Part No.	T	H	D	Suitable Cables	Nails(mm)
GB-1	7.0	4.8	Ø3	最大线径Ø3(3-5)	Ø1.5X21
GB-2	6.0	7	Ø4.6	最大线径Ø4.6(5-7)	Ø1.8X26
GB-3	8.8	9.20	Ø7	最大线径Ø7(7-10)	Ø1.8X26
GB-4	9.56	12.5	Ø9.5	最大线径Ø9.5(10-14)	Ø1.8X26
GB-5	11.8	17	Ø14.8	最大线径Ø14.8(14-20)	Ø2.5X40

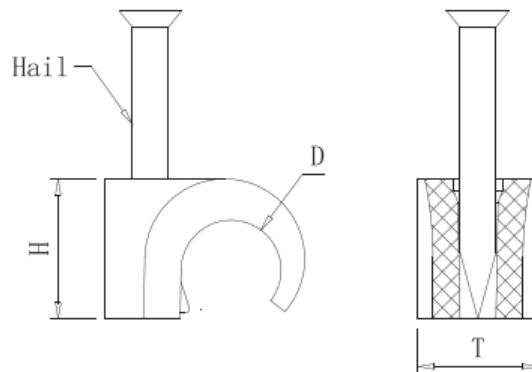

▶ **FLAT CABLE CLIP**

▶ 扁型电缆固定夹

- PE(white) ,fixable,good elasticity,to bear impact unable broken.
- Inserted nail,nail stick to plastic seat, save time and cost down
- Color: All color available
- Packing:100pcs/bag
- 本系列固定夹,均采PE(白色)射出成型,弹性大、耐冲击、绝不破裂
- 本系列固定夹,均为插钉式,钢钉直接附着于塑胶座上,可大量节省工时,降低施工成本.
- 颜色:各种颜色皆可.
- 包装:100个/包



Part No.	W	H	H1	Suitable Cables	Nails(mm)
GF-0.7	5.5	5.4	3.1	small flat wires	Ø2.0X15
GF-1.2	6.2	5.4	3.8	small flat wires	Ø2.0X15
GF-1.6	8.0	8.0	5.0	1.6mm white flat wires	Ø2.0X15
GF-2.0	8.5	8.0	5.2	2.0mm white flat wires	Ø2.5X18
GF-2.2	10.0	10.0	6.5	CNS 2.0mm white flat wires	Ø2.5X22
GFC-0.75	6.0	6.2	4.1		Ø1.5X18
GFC-1.5	9	7.8	5		Ø2.0X24
GFC-2.5	10.0	8.3	5.3		Ø2.0X24
GFC-4.0	11.4	9.6	6.5		Ø2.0X24
GFC-6.0	13.5	10.5	7.2		Ø2.0X29
GFC-10	17.2	11.6	8.6		Ø2.0X29
GFC-16	20.1	13.4	10.2		Ø2.5X34

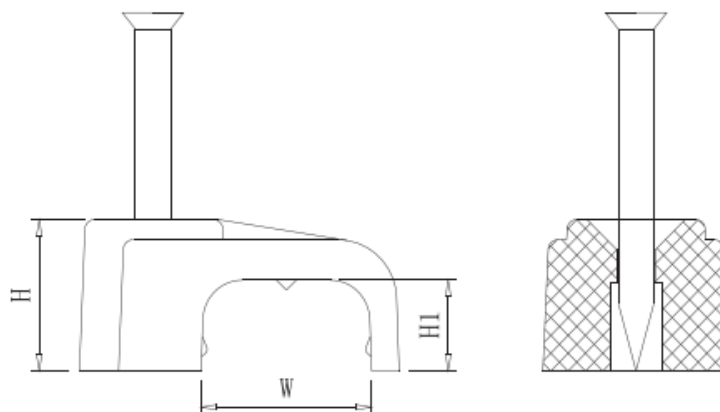

产品规格书

束线带系列 (Cable Tie Series)

► ECM-TYPE CABLE MARKER

ECM 型配线标志

- Material: Soft PVC,concave conversed shape,no.code in sleeve,elasticity of in-diameter.
- Usage:Peel each hack lightly.
- Feature:Suitable any size,special length and marking is available to order .
- Color: **All color available**
- 材质:用软质PVC料精制、形如倒凹形,管套上面印有文字代号,内径伸缩弹性很大.
- 使用:使用时将每个切离处轻剥下,即可配线.
- 特点:各种型号适合各种大小之配线,接受特殊长度或特殊标志之订制.
- 颜色:各种颜色皆可.

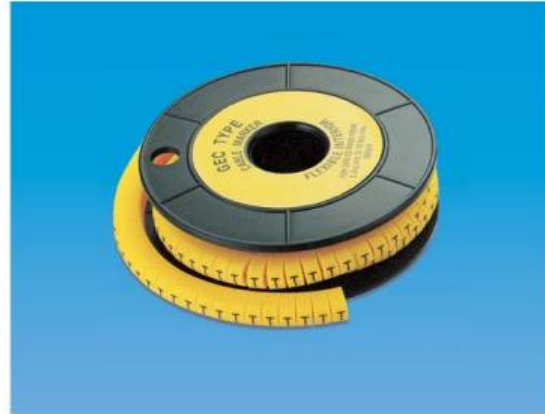

Part No.	Suitable Wire	In-Diameter(mm) R	Length(mm) L	NO.	Package
GEC-0	18AWG , 16AWG , 0.75 ,	2.0-3.2	3.5		1000PCS
GEC-1	0.75 , 1.25 , 2.0 , 3.0 ,	3.2-5.2	4.0	0-9 , A-Z , + , - , + ,	1000PCS
GEC-2	3.5 , 5.5 , 8.0 ,	3.6-7.4	5.0		500PCS
GEC-3	8.0 , 14.0 , 22.0 ,	5.2-10.0	5.5		250PCS

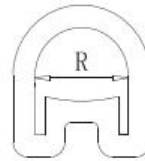
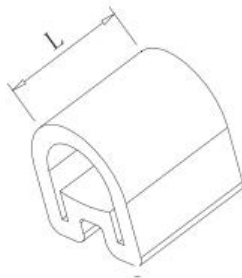

► FLAT CABLE MARKER

OFM 型配线标志

- Flat cable marker (with its unique oval shape design provides)
 - 1.Slip over cable directly (for small cable)
 - 2.Slip onto marker strip(for large cable or cable bundles)
- Material:Soft PVC,elasticity of in-diameter
- Color: **All color available**
- 配合标志靶, 替大电缆做记号.
- 材质:软质PVC,内径伸缩弹性大.
- 颜色:各种颜色皆可.



Part No.	Suitable Wire	In-Diameter(mm) W	Length(mm) L	NO.	Package
OFM-1	2~8	3.5~7.0	5	0-9 , A-Z , + , - , + ,	500PCS

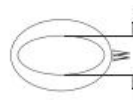

产品规格书

束线带系列 (Cable Tie Series)

OM-TYPE CABLE MARKER

OM 型配线标志

- Material: Soft PVC, flexible, transfigure hardly.
- Construction: No. code printed in length 10m/m.
- Feature: Provide wire marking, install easily and insulation.
- Color: All color available
- 材质: 采用软质PVC料精制、伸缩性大, 不易变形.
- 构造: 长度10m/m上印有文字标志.
- 特点: 供一般电线标示, 易安装又可绝缘
- 颜色: 各种颜色皆可.



Part No.	Suitable Wire Name	Wire In-Diameter(mm)	Length	NO.	Package
GOM-0.75	0.75sq	3.0	10mm	0-99, A-Z, +, -, +, +	100pcs
GOM-1.25	1.25sq	3.2			
GOM-2.0	2.0sq	3.6			
GOM-3.5	3.5sq	4.2			
GOM-5.5	5.5sq	5.1			
GOM-8.0	8sq	6.2			

MOVABLE BUSHING

绝缘保护套

- Material: PE.
- Usage: Use suitable length to wrap the slot hole by slot hole size.
- Feature: Insulation of wires suit slot hole size, usage is free.
- Color: All color available
- 材质: PE.
- 使用: 依出线孔大小, 取所需之长度, 再其卷绕于线孔上.
- 特点: 电线电缆之保护绝缘合出线孔大小形状不规则之使用.
- 颜色: 各种颜色皆可.



Part No.	Duct Dia	Suit. Iron Thick	Package
GMB-10	1.0	below 1.0	10m/bag
GMB-16	1.6	1.0-1.6	
GMB-20	2	1.6-2.0	
GMB-24	2.4	2.0-2.4	
GMB-32	3.2	2.4-3.2	
GMB-45	4.5	3.2-4.5	

WRAPPING BAND

卷式结束带

- Material: PE.
- Usage: Use suitable length and fixed in one end by cable tie then wrap in direction of clockwise
- Feature: Strong tensible, won't change shape after second usage, special color is available.
- 材质: PE.
- 使用: 取所需之长度, 以扎线带固定一端再将卷束带依顺时针方向卷绕.
- 特点: 结束力强, 二次使用不变形, 为配美观, 接受各种特殊颜色订制.



Part No.	In-Diameter(mm)	out-Diameter(mm)	Screw Diameter (mmØ)	Wrapping Range (mmØ)	Package
GST-4	5.0	6	7.0	4-50	10M/bag
GST-6	7.0	8	10.8	6-60	
GST-8	8.5	10	11.4	7.5-60	

Part No.	In-Diameter(mm)	out-Diameter(mm)	Screw Diameter (mmØ)	Wrapping Range (mmØ)	Package
GST-9	10.2	12	13.9	9-65	10M/bag
GST-12	13.0	15	15.0	12-70	
GST-15	16.4	19	18.2	15-100	
GST-20	21.0	24	19.6	20-130	

NYLON CABLE GLAND

尼龙电缆固定头

- Time saving ,cable can be easily once inserted into through the gland without dismantling the parts.
- Material:UL nylon66;neoprene for seal insert , with nut.
- Temp. resistance: -30°C to 80°C;short time 140°C
- Color:Black ,grey, light grey.
- 特点:1.夹紧圈经特殊设计,拉力强,对电缆不造成损伤
2.不须将固定头解体,电缆可直接穿入上紧即可,省时方便.
- 用途:一般机械控制箱、配电房、机器、电器等电缆固定用。
- 材质: 尼龙66,防火等级94V-2.
- 工作温度:-30 °C ~ 80°C
- 颜色:黑、灰、浅灰.



Part No.	D1(mm)	D2(mm)	B1(mm)	L1(mm)	L2(mm)	L3(mm)	D(mm)	E(MM)	Cable Range
Nylon PG Gland Range									
PG-7	13	6.5	7.5	8	12.2	14.5	5	19	3~6.5
PG-9	15.7	8.5	9	7.5	15.7	15.6	5	22	4~8
PG-11	19	10.5	11	8	15.1	17.2	5	24	5~10
PG-13.5	21	12	12	10	17.4	18	6	27	6~12
PG-16	23	14	14	10	16.8	19.2	6	30	10~14
PG-21	28.8	18	19.7	11	20.3	22.6	7	36	13~18
PG-29	37.5	25	26.6	11	20.5	26.4	7	45.5	18~25
PG-36	47.5	35	35.3	12	27.5	30	8	59.5	22~32
PG-42	54.5	38	38	14.6	29	32.5	8	64.5	28~38
PG-48	60	45.5	45.5	15.5	30.6	34.5	8	69.5	35~45
Metric Gland Range									
M12	12.5	6.5	7.5	8	12.2	14.5	5	17	3~6.5
M16	15.7	8.5	9	7.5	15.7	15.6	5	22	4~8
M20	20.5	12	12	10	17.4	18	6	26	6~12
M25	25.5	18	19.7	11	20.3	22.6	6	32	13~18
M32	32.5	25	26.6	11	20.5	26.4	7	41	18~25
M40	40.5	25	26.6	11	21	26.4	7	50	18~25
M50	50.5	35	35.3	12	27.5	30	8	59.5	25~35
M63	63.5	45.5	45.5	13.5	30.6	34.5	8	74.5	35~45

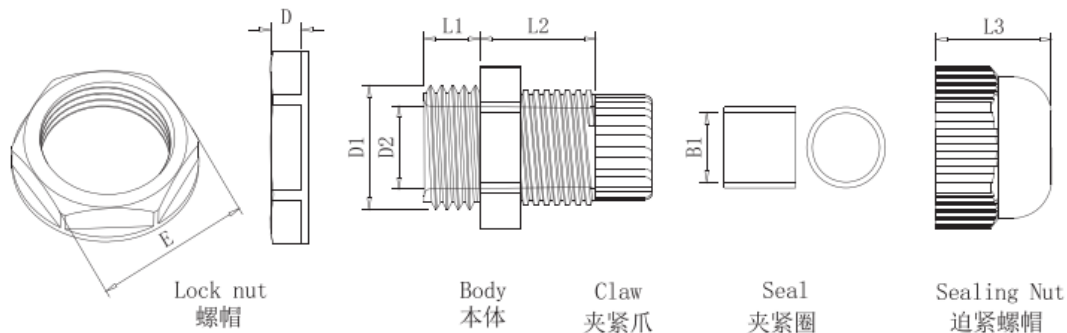

产品规格书

束线带系列 (Cable Tie Series)

▶ CLOSE-END CONNECTOR

闭端端子

- Close-end connector with internal tin plated copper tube to ensure perfect connections between wires.
- Just strip of the wire and insert securely inside the connector, crimp by crimping tool.
- Material: UL approved Nylon 66, 94V-2
- 用法: 电线剥去外皮插入端子内, 用工具压着即可, 适用于各种电器产品, 灯饰, 家庭配线等接线器材, 接触良好不脱落
- 材质: 尼龙66, 防火等级94V-2.
- 电压: 300V (Voltage: 300V)
- 温度: 105°C (Temperature: 105°C)
- 国际认证: 通过美国UL, 加拿大CSA安全测试.



Part No.	dØ	DØ	D1Ø	L	I	Suitable Wire mm2	Wires A.W.G.	Suitable Crimping Tool	Package
C3	2.5	6.5	5.1	18.0	6.4	1.25	22-16	YM-300	1000PCS
C4	3.1	7.8	5.7	20.1	8.0	2.0	16-24		
C5	4.3	10.6	7.3	24.8	10.7	5.5	12-14		
C8	5.0	12.0	9.1	27.1	12.5	8.0	8.0	YM-480	500PCS

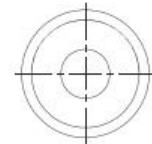
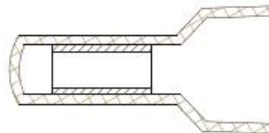
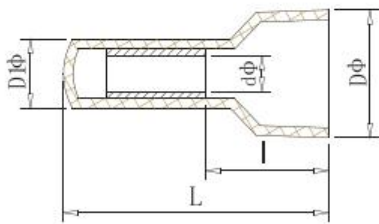

▶ ALL PLASTIC WIRE CONNECTOR

旋转端子

- Extruded PVC fire-resistance materials.
- Without spring square steel wires inside.
- Easy for wire entrance and eliminates wire strands hang up.
- 材质: PVC防火材质.
- 用法: 连接电线, 内有螺纹, 使用时先剥去电线外皮, 再插入接头内, 旋转即可



Part No.	Tem Rating	Voltage	Dimension					Package	A.W.G.	Color
			A	B	C	D	E			
H1	100°C	300V	3.2	6.5	8.8	4.4	15.2	1000pcs	22-16	Yellow
H3			4.0	7.9	10.1	4.8	18.7			Lvory
H5	100°C		4.0	8.9	11.2	10.3	23.6	1000pcs	22-14	Yellow
H6	105°C		4.0	10.5	14.0	15.0	27.5	500pcs	Lvory	

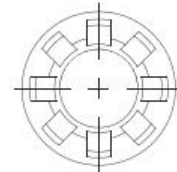
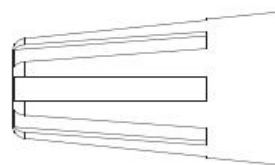
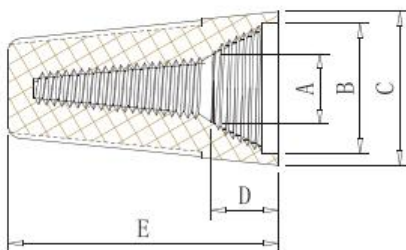

► SCREW ON WIRE CONNECTOR

► 弹簧螺式接头

- Extruded PVC fire-resistance materials.
- Inner assembled with spring square steel wires.
- Easy for wire entrance and eliminates wire strands hang up.
- 材质:PVC防火材质.
- 用法:连接电线,内附弹簧,旋转时弹簧夹紧电线,不易脱落.



Part No.	Tem Rating	Voltage	Dimension							A.W.G	Color	Package
			ØA	ØB	ØC	ØD	E	F	ØG			
E1	105℃	300V	3.0	5.0	6.0	8.5	3.5	14.7	5.2	22-16	Gray, Yellow, Orange	1000pcs
E2			4.0	6.0	7.5	10.1	5.0	17.5	6.5	22-14	Blue, Yellow, Black Orange, Dark orange	1000pcs
E3		600V	4.2	6.2	8.2	11.2	8.0	21.4	8.3	22-14	Orange, Yellow, Dark orange	500pcs
E4			5.2	8.0	10.5	13.7	7.0	23.6	10.5	18-12	Yellow, Dark orange	500pcs
E5			7.0	10.0	13.0	16.0	7.0	26.5	12.0	18-10	Red	250pcs
E6			8.3	13.5	18.4	8.8	32.2	26.5	12.5	22-16	Gray	100pcs
E11			300V	3.0	5.0	6.0	8.5	3.5	14.7	5.2	20-18	Black

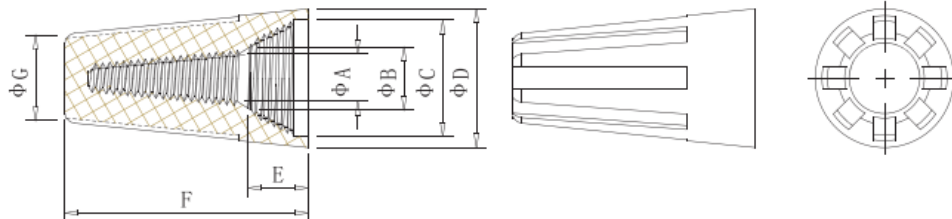

► WING GUARD WIRE CONNECTOR

► 双翼弹簧旋转端子

- Easy for wire entrance and eliminates wire strands hang up.
- 用法:连接电线,内附弹簧,旋转时弹簧夹紧电线,不易脱落.



Part No.	Tem Rating	Voltage	Dimension					Package	A.W.G.	Color
			A	B	C	D	E			
Y11	105℃	300V	5.3	8.8	17.8	8.5	25.8	500pcs	10-18	Yellow
Y12			6.9	11.6	23.9	9.2	31.7		10-18	Red
Y13		600V	10.4	14.5	27.1	9.5	33.3	100pcs	8-14	Gray
Y14			9.1	17.6	30.4	11.4	39.3		6-12	Blue

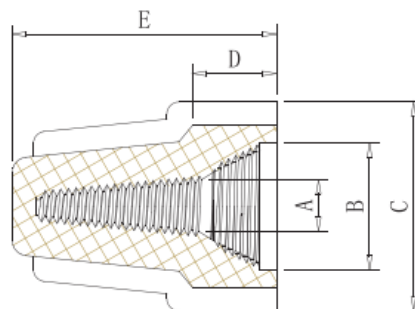

◆ 关于规格表以外的特殊尺寸,我们会按照贵公司提出的相应要求来进行生产。

产品材质报告

产品名称: 束线带 (GN系列)

报告日期: 2019年9月6日

成份表				
Composition table				
序号	材料名称	CAS No.	含量 (%)	备注
1	Poly[imino(1,6-dioxo-1,6-hexanediy)] imino-1,6-hexanediy] 尼龙66(nylon 6/6)	32131-17-2	99 - 100	
合计				

合格证 (样张)

品名	扎带
规格	GN-200I/蓝色
数量	(1000PCS/包*4) *1包=4000
生产日期/批号	190827
有效期	2年
存储条件	密封遮光保存, 使用前不要打开包装袋

上海高昊配线器材有限公司 www.gaohaocn.com

PA66 材料物性表

材料名: PA66

实验项目 Test Item	单位 Unit	PA66	
		实验要求	实测值
拉伸强度 Tensile Strength	Mpa	23°C干燥值	83
伸长率 Elongation	%	23°C干燥值	40
电气绝缘实验 Volume Resistivity (20°C)	$\Omega \cdot m$	23°C干燥值	6.0x10 ¹⁵

束线带测试规范及客户使用注意事项

一、测试规范

拉力测试机

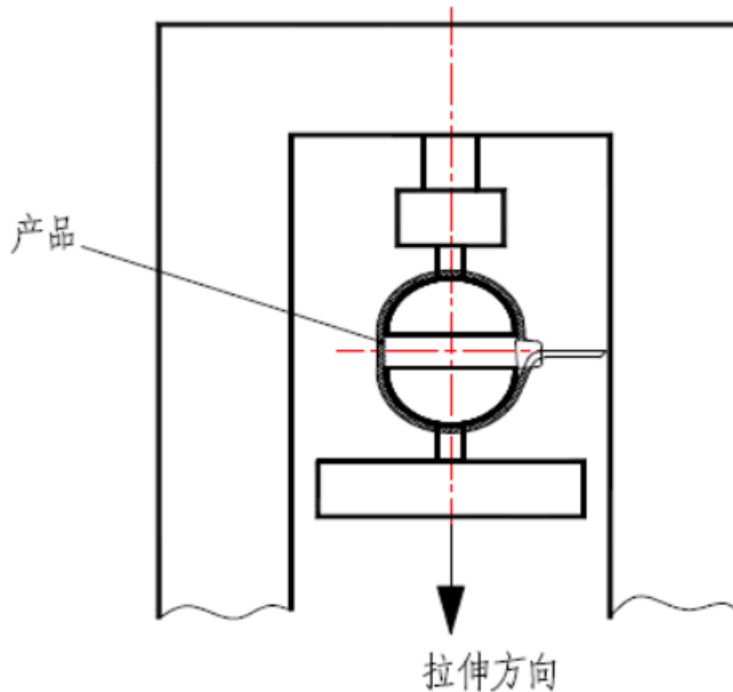

测试条件:

速度: 25mm/min

测试机器: 宏达微电脑万能材料测试机

治具: 圆周状

说明: 以产品2/3 有效长度束紧于治具上。

二、使用注意事项

1. 在尚未使用前应注意包装袋的密合, 不可打开包装, 以免产品水分蒸发而发生脆硬, 每个独立包装之产品未使用完毕应将封口重新密合。
2. 束线带存放于温度不良之场所时 (如冬季期间室温在 0°C 时等), 使用前请先置于室温 (20°C) 2 小时后使用。
3. 束线枪使用之相对应刻度: (束线枪型号GIT-703, 使用优点为快速拉紧并切断。)
 - M 系列 (束线带宽度2.4~2.5mm) 束线枪刻度调整范围1~3
 - I 系列 (束线带宽度3.6mm) 束线枪刻度调整范围4~6
 - ST 系列 (束线带宽度4.8mm) 束线枪刻度调整范围7~8
4. 使用束线枪时应注意切口情形调整束线枪刻度, 以切口长出头部约2mm 为最佳。切口内缩入束线头部为束紧力过大, 会导致松脱。切口预留过长为束紧

力偏小，适用于对束紧程度较松之情形。

5. 束紧时应注意束线带不可发生扭转，如此会破坏头内齿部，易造成松脱。
6. 使用束线枪束紧时若发生产品被拉长不易切断时可将束线枪的刻度适当调低即可改善。如发生拉长而未将力度调整小会发生带身拉长变形与头内齿部咬合不良而发生松脱。
7. 应避免束线枪使用时刀口钝而将束线多次拉紧磨合可能将头内齿部磨损从而发生松脱。
8. 根据束线枪使用之频率，客户应定期对束线枪的力度做调校。
9. 若无专用束紧之工具，在穿入带身时应避免快速穿带，尤其冬季束线随气温降低而带身变硬，更应注意穿带的速度。避免因带身穿带速度过快，带身将头内齿部磨损而导致束线带扎不紧松脱之现象。
10. 束紧时应注意不可将产品束紧于棱角较尖锐之物体。
11. 束紧后应避免高频震动或摔落。
12. 产品在换季时应考虑库存品是否为不同季节产品，特别在夏季产品转换冬季使用。通常夏季产品含水率较低，在冬季使用时应该做补水作业。
13. 存储环境应考虑是否有在控温环境，最佳存储温度在 $23^{\circ}\text{C}\pm 3^{\circ}\text{C}$ 。环境相对湿度应保持在40%~60%之间。
14. 存储环境在常温状态下应避免阳光直射、高温。